

NDP-15 Specifications

Port Dimensions (13.5 GPM Max.)

Intake & discharge connection:

Polypropylene (PPG) ■	1/2" Female NPT
Kynar® (PVDF) ◆	1/2" Female NPT
Groundable Acetal ◆	1/2" Female NPT
Aluminum (ADC-12) ▲	1/2" Female NPT
Stainless Steel (316) ▲	1/2" Female NPT
Air inlet (includes ball valve):	1/4" Female NPT
Air exhaust (internal silencer):	3/8" Female NPT

- Polypropylene pumps may be fitted with ball or flat check valves. Ball-type check valves are recommended for flooded suction applications. Flat-type check valves are recommended for suction lift applications.
- ◆ Kynar® and Groundable Acetal pumps are fitted with flat check valves only.
- ▲ Aluminum and Stainless Steel pumps are fitted with ball check valves only.

Maximum Liquid Temperature*

Diaphragm Material	Temperature
Neoprene	180°F (82°C)
Buna N	180°F (82°C)
HytreI® (TPC-ET)	248°F (120°C)
Santoprene® (TPE)	212°F (100°C)
Viton® fluoroelastomer	248°F (120°C)
Teflon® (PTFE)	212°F (100°C)

*The maximum liquid temperature for metal and Kynar®-fitted pumps is determined by the elastomer (diaphragm material). Polypropylene and Groundable Acetal pumps have a maximum liquid temperature of 180°F (82°C) regardless of diaphragm material.

Air Supply Pressure (All Models)

20–100 PSI (1.4–7 kfg/cm)

Discharge Volume Per Cycle

0.0338 gallons (128 cc)

Maximum Cycles Per Minute

All diaphragms: 400

Maximum Size Solid: 1/32" (1 mm)

Maximum Dry Suction Lift

Flat-type check valve: 8-feet

Ball-type check valve: 5-feet

Pump Air Motor: Ryton® air motor standard

Notes: HytreI®-fitted pumps include Buna N check balls & wetted o-rings. Santoprene®-fitted pumps include EPDM check balls & wetted o-rings.



Aluminum

Dimensions: 8.66" W x 10.71" H

Net Wt.: 9 lbs. (4 kg)

Shipping Wt.: 11 lbs.

Stainless Steel

Dimensions: 8.31" W x 9.7" H

Net Wt.: 13.6 lbs. (6.16 kg)

Shipping Wt.: 15.5 lbs.

Kynar® (PVDF)

Dimensions: 8.66" W x 11.73" H

Net Wt.: 9.4 lbs. (4.2 kg)

Shipping Wt.: 11 lbs.

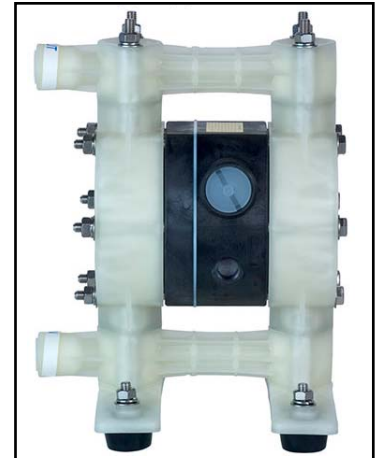
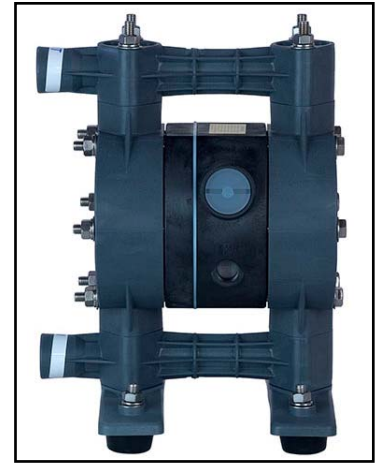

Groundable Acetal

Dimensions: 8.66" W x 11.73" H

Net Wt.: 9 lbs. (4 kg)

Shipping Wt.: 11 lbs.

Polypropylene

Dimensions: 8.66" W x 11.73" H

Net Wt.: 7.7 lbs. (3.5 kg)

Shipping Wt.: 9.5 lbs.

Model Number Nomenclature

Series: NDP-15 x x x
Pump

Valve Type:

B = Ball
F = Flat*

Body Material:

P = Polypropylene
V = Kynar® (PVDF)
D = Groundable Acetal
A = Aluminum
S = Stainless Steel

Diaphragm Material:

C = Neoprene (CR)
N = Buna N (NBR)
S = Santoprene® (TPO)
T = Teflon® (PTFE)
V = Viton® (FPM)
H = HytreI® (TPE)

* Flat valves are available for plastic pumps only.



NDP-15 Performance Curve — All Valves

All Diaphragm Materials

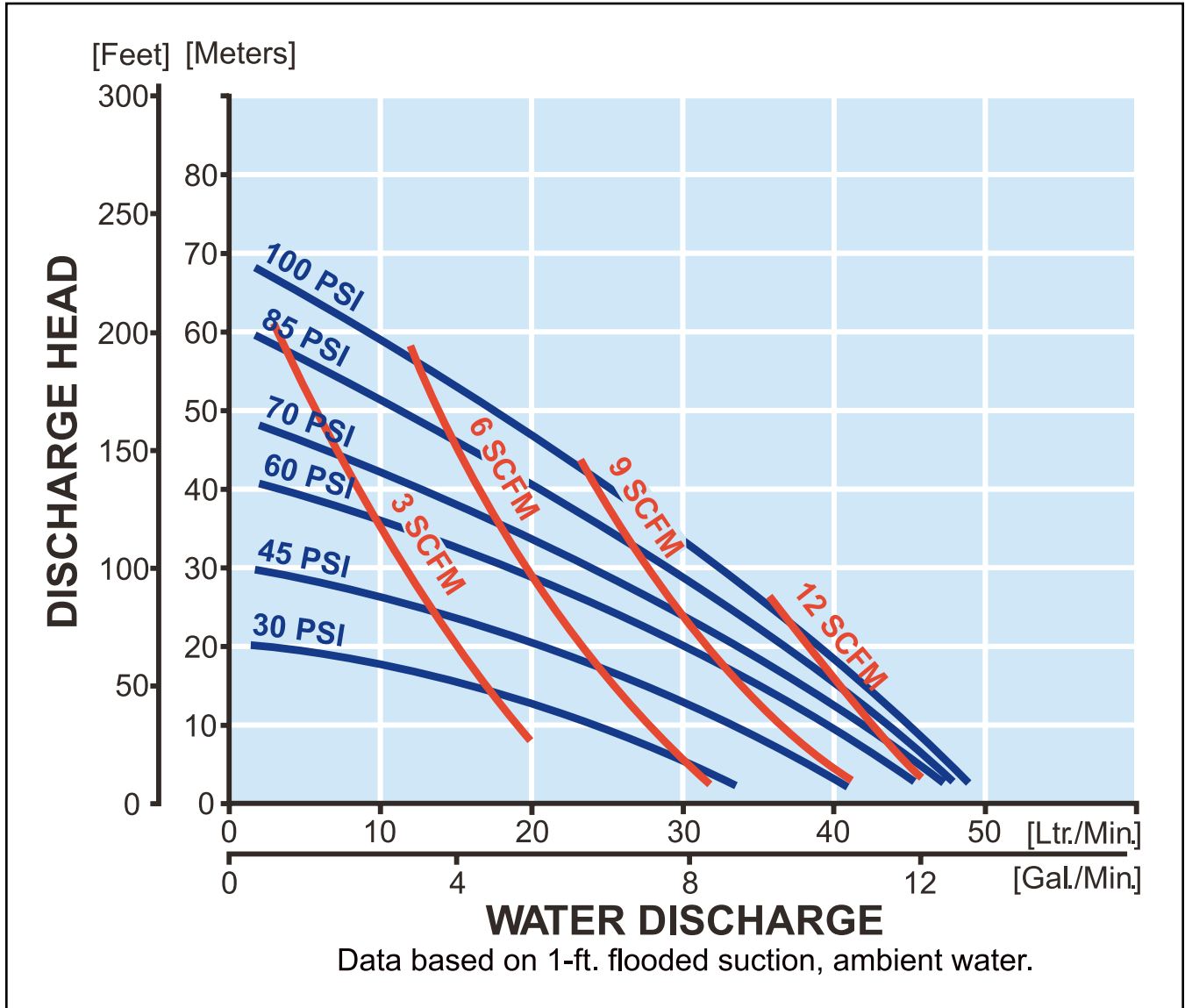

To calculate performance for Santoprene® and Hytrel®-fitted pumps, use Rubber Diaphragm Curve.