

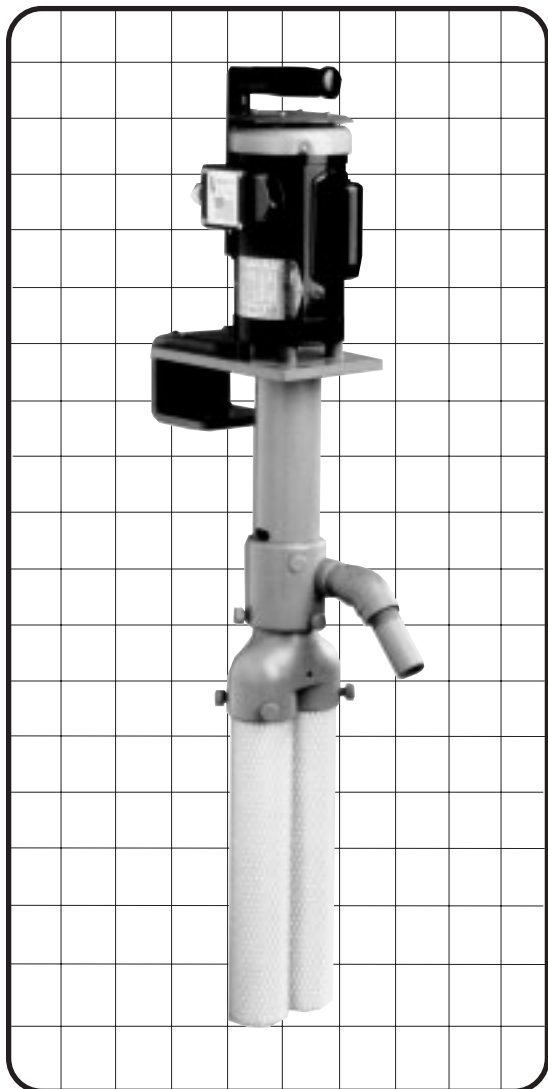

THE FLO KING BX3000



- A FLOW RATE OF 3000 GPH (11,000 LPH) USING A TOTALLY ENCLOSED, FAN-COOLED, 1/3-HP MOTOR
- GREAT FOR TANKS OF INTER-MEDIATE SIZE OR AGGRESSIVE AGITATION AND FAST CLEANUP OF SMALLER TANKS
- BUILT IN SEVERAL LENGTHS FOR MOST TANK CONFIGURATIONS
- A CLEAN SOURCE OF AGITATION ... AN ALTERNATIVE TO AIR OR MECHANICAL AGITATION
- USE IN ONE TANK OR AS A UTILITY UNIT IN MANY TANKS
- CHANGE FILTERS QUICKLY ... NO TOOLS, NO DOWNTIME

**No plumbing, clamping or costly installation.
Complete, ready to operate—out of the box and into your tank.
No leaks, no spills!**

★ IF YOU NEED A FILTER SYSTEM TOMORROW CALL US TODAY ★

Pioneers of In-Tank Filtration ★ www.floking.com



THE FLO KING BX3000

The BX3000 provides a maximum flow rate of 3,000 gallons per hour. Use it stationary on one tank or move it from tank to tank. Multiple body lengths (8", 10", 12", 14", 16", 18" and 20") enable use of the BX3000 in tanks with varying solution levels and depths. The BX3000 comes complete, preassembled, and ready to operate and includes the items shown in the labeled photograph below. For best results in most metal finishing solutions, use the BX3000 with our PMCA Permacore Magnum reusable or FK50 Poly-Spun disposable filter cartridges in the appropriate length.

FLO KING BX3000 SPECIFICATION

PUMP: All-CPVC or polypropylene construction with Teflon-covered stainless steel shaft. Pump also available in PVDF/Kynar (call for pricing) and stainless steel (see Bulletin 23.5).

FLOW RATE: 3000 gallons per hour (11,000 liters per hour) at 60 Hz. A flow-rate reduction of 18%(±3%) is typical when operated at 50 Hz.

PRESSURE: 27 feet (8.2 meters) of head pressure

WEIGHT: About 24 pounds (10.5 kg), depending on pump body length

MOTOR: Epoxy-coated, TEFC, Thermally Protected. Available in single phase, 1/3 HP (250 watt), 120/240 V, 6.0/3.0 A, 50/60 HZ, 2850/3450 RPM. Specify voltage when ordering. *Call for information on 3-phase motors.*

RUNNING PUMP DRY DOES NOT DAMAGE MOTOR, PUMP, SEALS OR BEARINGS

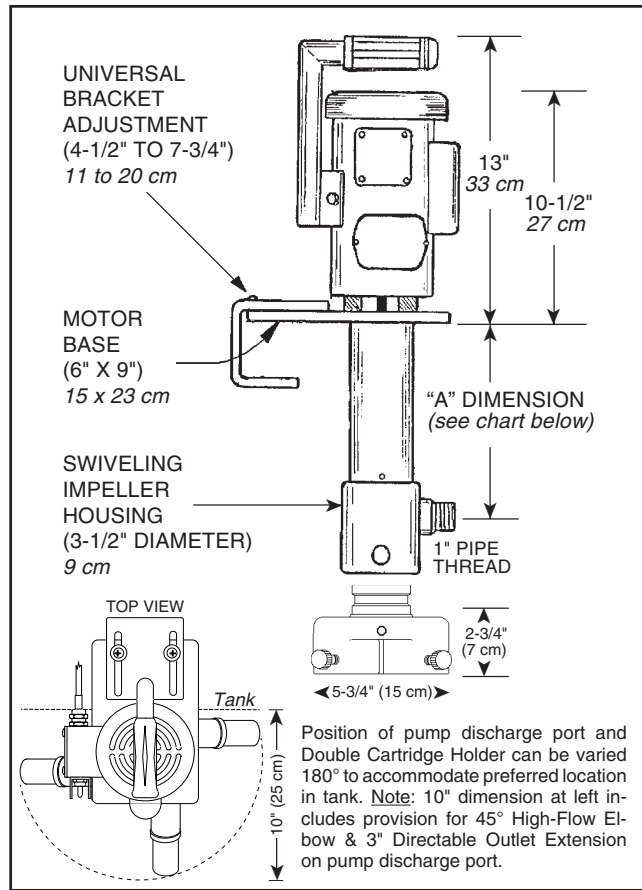
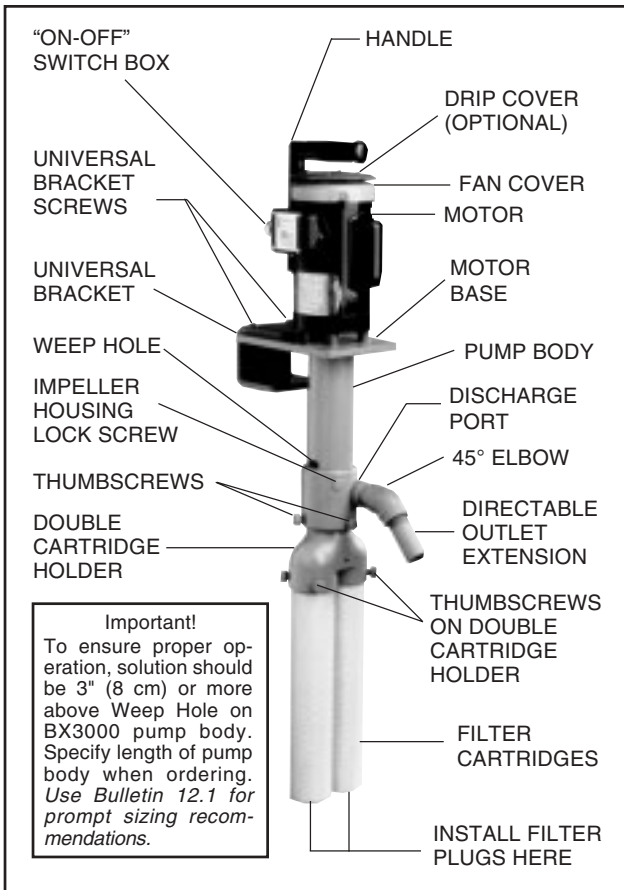

MEASUREMENT FROM BOTTOM OF MOTOR BASE TO DISCHARGE PORT ("A" DIMENSION)

PUMP MODEL	BX3000-8	BX3000-10	BX3000-12	BX3000-14	BX3000-16	BX3000-18	BX3000-20
"A" DIMENSION	8-3/4" (22 cm)	10-3/4" (27 cm)	12-3/4" (32 cm)	14-3/4" (37 cm)	16-3/4" (43 cm)	18-3/4" (48 cm)	20-3/4" (53 cm)