

METALMAG[®] LINE

ULTRAChem[®]

ANSI DIMENSIONAL MAG DRIVE

*Engineered for
EXTREME reliability
in chemical processes.*



Pat. No. 5,779,456



FINISH THOMPSON INC.

Extreme situations call for extreme measures. Finish Thompson's ULTRAChem® is a magnetically driven, ANSI dimensional pump engineered for the utmost reliability in even the most extreme chemical processing applications.

ULTRAChem® has a tough ductile iron casing with a lining of DuPont™ Tefzel® (ETFE) for superior corrosion resistance. The casing meets ANSI/ASME B73.1M nozzle loads.

Engineered for EXTREME Reliability in Chemical Processes

Longer pump life was designed into ULTRAChem® from its inception. The modified concentric volute equalizes pressure across the entire flow range allowing minimal hydraulic radial thrust loads. Wear on pump components is decreased.

Rear sealing ring and impeller balance holes balance hydraulic axial thrust loads decreasing pressure on the impeller.

Straightening vanes in the suction prevent "pre-rotation" under low flows and reduce turbulence on the impeller for enhanced low flow operation.

Unique dual bushings provide optimum alignment. Bushings ride evenly on the shaft while spiral bores provide lubrication.

Powerful neodymium magnets drive the impeller for dependable, leak-free operation with no environmental emissions. No seals to replace.

ULTRAChem® performs efficiently with greater reliability and lower maintenance requirements for increased productivity and minimal operating costs in chemical process applications. It is the best value in ANSI dimensional pumps in the chemical process market.

Lining of DuPont™
Tefzel® fluoropolymer resin

ANSI DIM

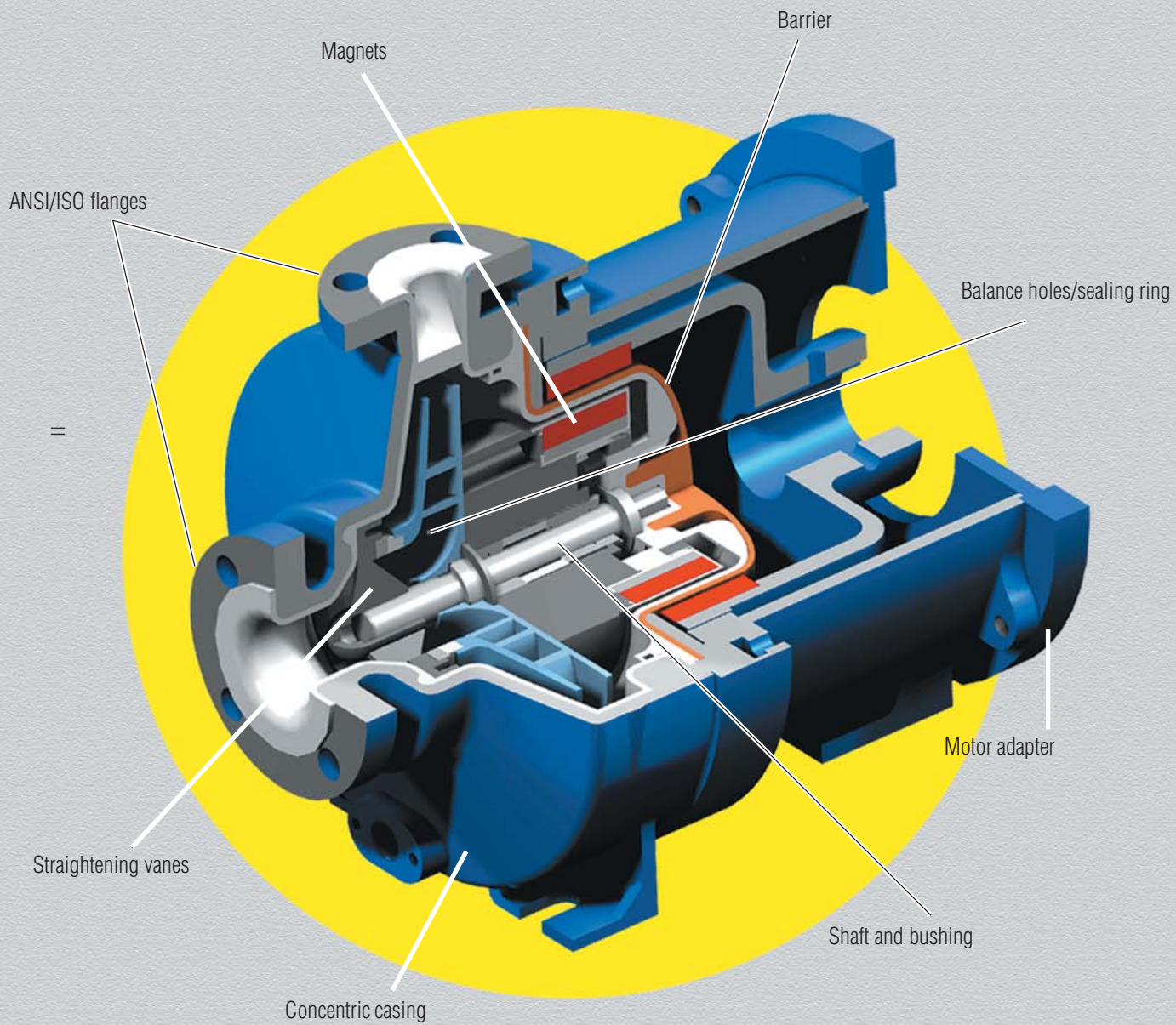

ENSIONAL

UNIVERSAL FEATURES:

Casing Dimension: ANSI/ASME B73.1m
Working Pressure: 175 psi (12 Bar)
Maximum Temperature: 250°F (121°C)
Motor Horsepower to 20 (15kW)

Maximum Viscosity: 200 cP
Flange Mounting: ANSI or ISO
Motor Frames: NEMA 143, 184, 215, 256
 IEC 80, 90, 110/112, 132, 160

Model **UC1516**

Suction: 1-1/2 in. (38 mm)
Discharge: 1 in. (25 mm)
Impeller: 6-3/8 in. (162 mm)
Max Flow: 160 gpm (37 M³Hr)*
Max. Head: 180 ft. (55 M)*



Model **UC326**

Suction: 3 in. (75 mm)
Discharge: 2 in. (50 mm)
Impeller: 6-3/8 in. (162 mm)
Max Flow: 330 gpm (75 M³Hr)*
Max. Head: 165 ft. (50 M)*



Model **UC1518**

Suction: 1-1/2 in. (38 mm)
Discharge: 1 in. (25 mm)
Impeller: 8-1/8 in. (206 mm)
Max Flow: 160 gpm (37 M³Hr)*
Max. Head: 325 ft. (100 M)*



* calculated at 3500 rpm.

UC Series

Standard Horizontal
Performance Curves

3500 rpm, 60 Hz

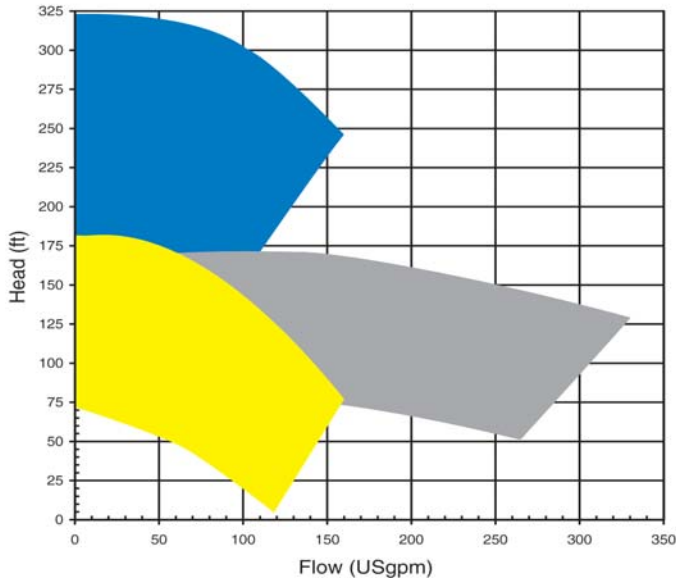

2900 rpm, 50 Hz

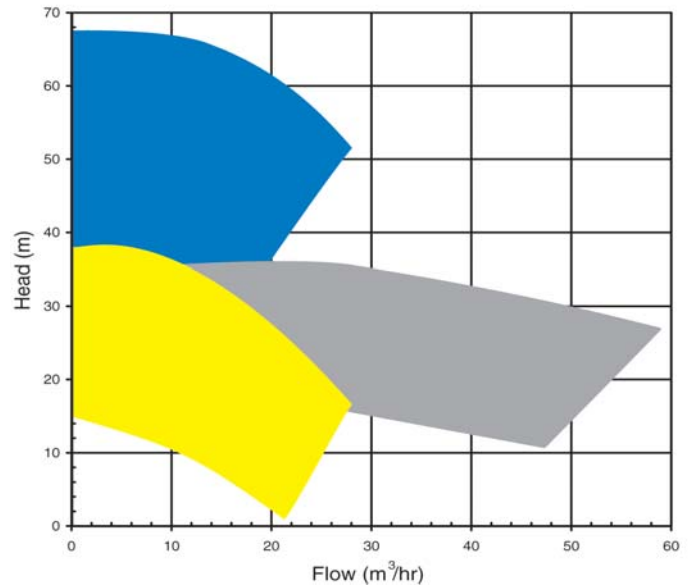

UC1516
1-1/2 x 1 x 6 in.
38 x 25 x 162 mm

UC326
3 x 2 x 6 in.
75 x 50 x 162 mm

UC1518
1-1/2 x 1 x 8 in.
38 x 25 x 206 mm

1750 rpm, 60 Hz

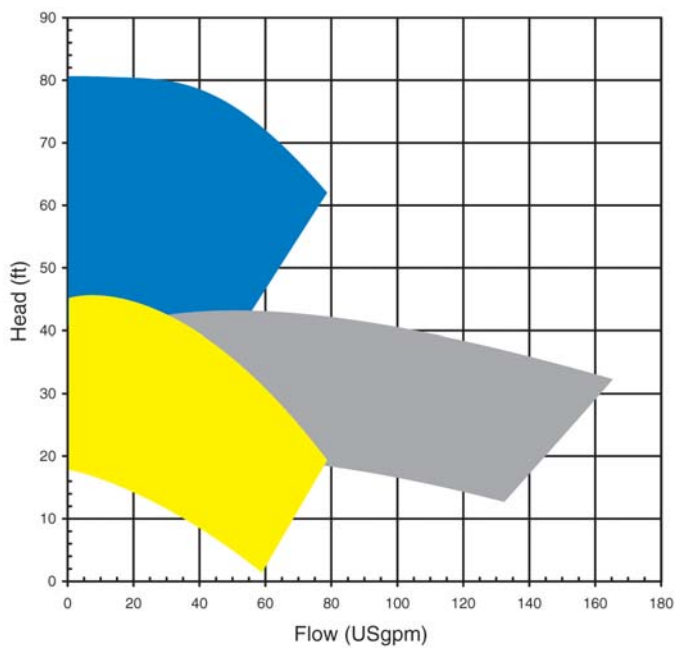

1450 rpm, 50 Hz

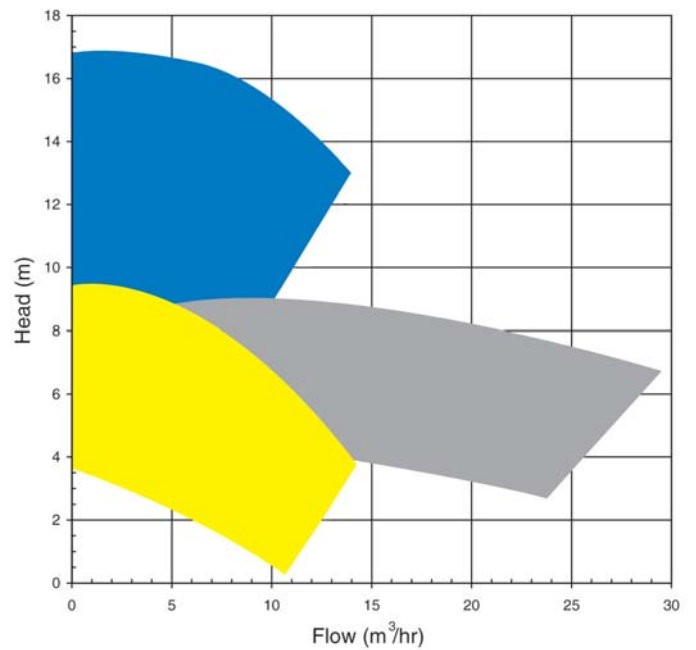

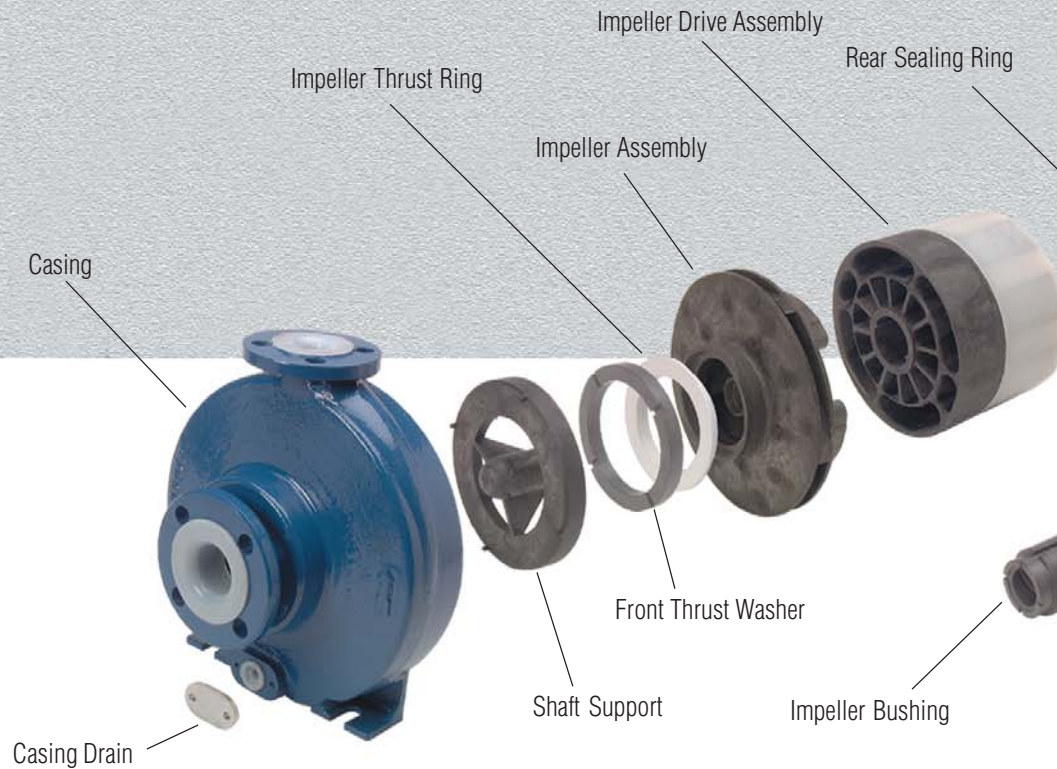

DESIGN FEATURES

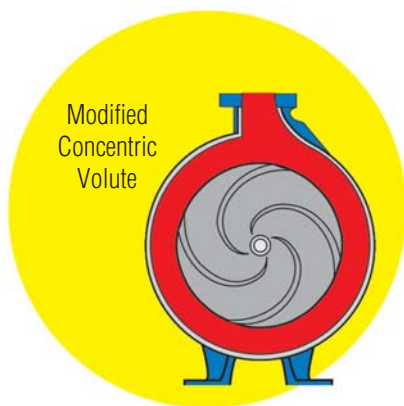

- **Casing**

High strength ductile iron bonded with pure ETFE for best corrosion resistance. ANSI dimensional design with top center line discharge. The **modified concentric volute** minimizes radial loads and distributes pressure evenly across the entire flow range for less stress and wear on components. Casing drain is standard. Back pull-out design for ease of maintenance.

- **Impeller and Internal Drive Hub**

Enclosed impeller is injection molded from carbon fiber reinforced ETFE for superior corrosion resistance. Versatile lock-fit design allows for easy accessibility to impeller. Generous impeller balance holes reduce axial thrust loads and lighten pressure for decreased stress on impeller. Internal drive hub has pure ETFE encapsulated magnets for added protection against aggressive fluids.

- **Drive Assembly and Motor Adapter**

Heavy duty ductile iron for added mechanical strength and stiffness. Motor adapter accepts NEMA or IEC motors.

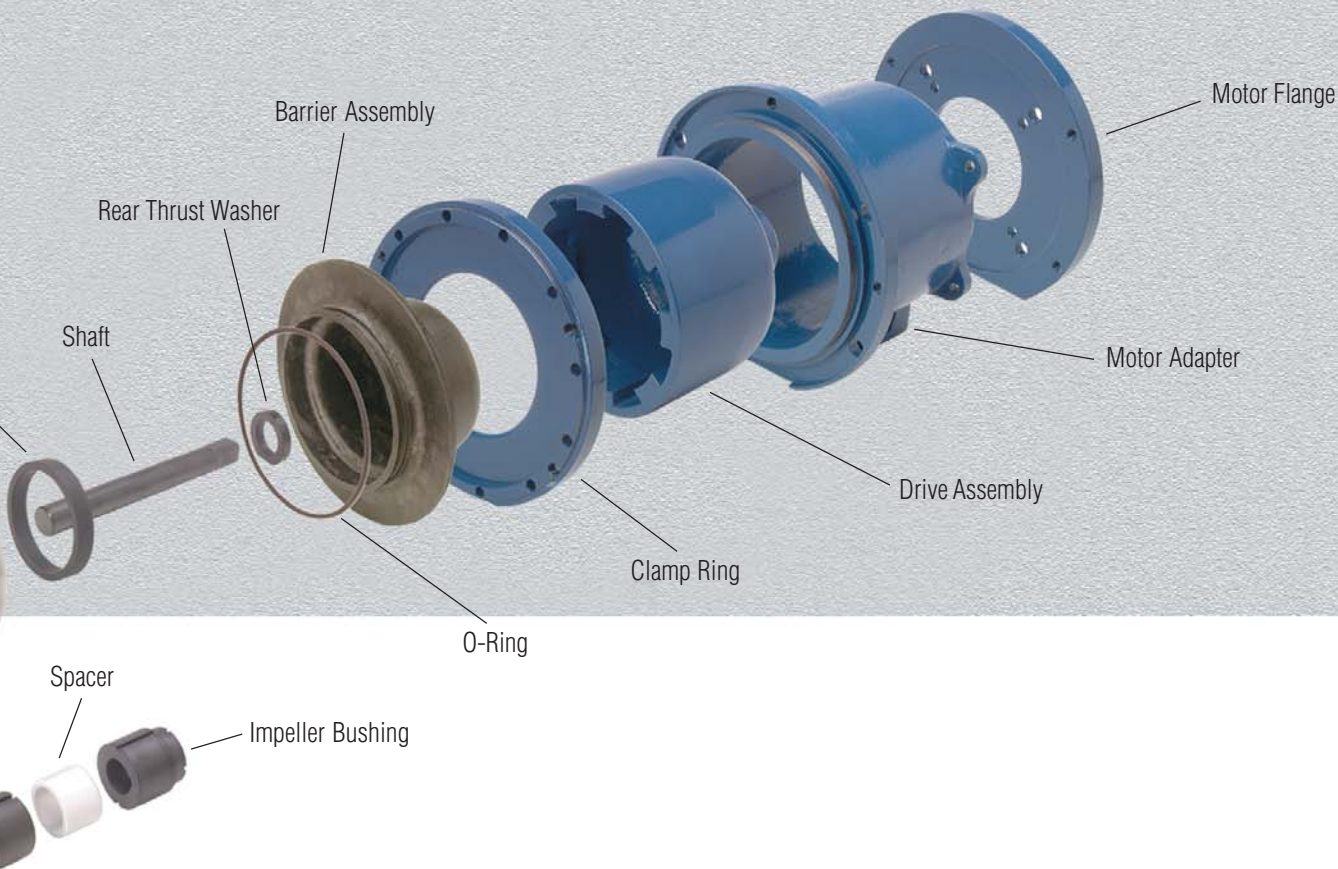

- **Magnets**

High strength, rare earth neodymium boron iron for maximum power and reliability. **FTI's unique magnetic technology** ensures an extraordinarily strong, secure coupling between the motor and pump. Sealless design virtually eliminates maintenance and environmental emissions.

- **Shaft**

Replaceable sintered silicon carbide shaft. Carbon-filled ETFE shaft support with integral straightening vanes prevents pre-rotation in suction and enhances low flow operation. Turbulence is reduced and stress on impeller decreased.

- **Dual Bushings**

Sintered silicon carbide bushings ride evenly on the shaft for optimum alignment and reliability. Internal spiral grooves on the bushing help flush and lubricate shaft during operation. Optional carbon bushing allows run dry capability.

- **Rings**

Front wear ring and rear sealing ring have the same diameter for better hydraulic balance. The front wear ring is manufactured from Fluorosint® that provides exceptional wear characteristics at all flows.

- **Barrier**

A precision molded, carbon-filled ETFE liner with an external containment shell of woven glass-reinforced vinyl ester make up the barrier assembly. Barrier construction provides optimum chemical and pressure resistance. The internal o-ring utilizes the liner strength and internal pressure for a leak-free seal.

- **Clamp Ring**

Steel ring provides a matched fit on the barrier to minimize barrier stress and deflection under pressure for maximum operating reliability.

DIMENSIONS

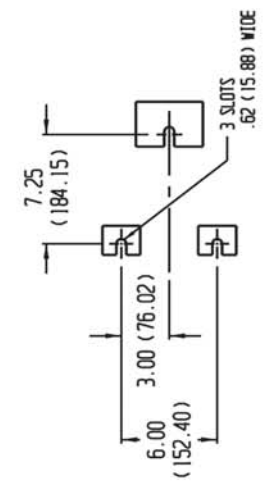
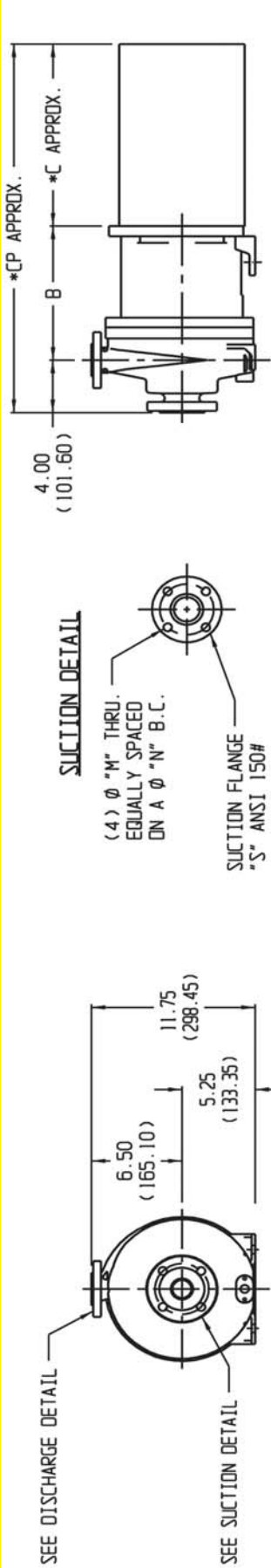

DISCHARGE DETAIL

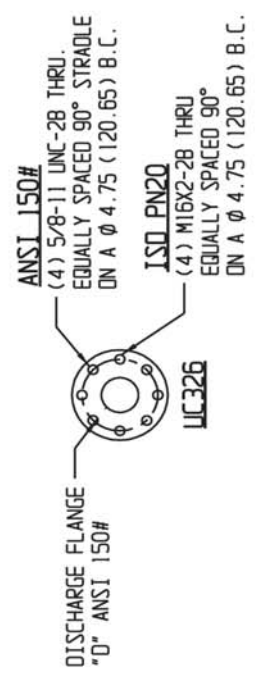

UC WITH OPTIONAL BASE PLATE

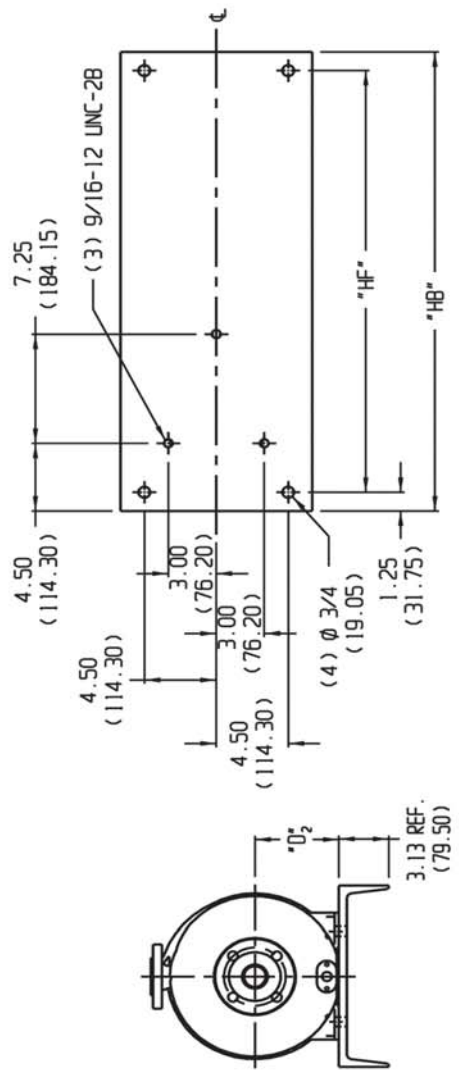

* MOTOR DIMENSIONS MAY VARY BY MANUFACTURER

** DRAWING FOR REFERENCE ONLY
(DO NOT USE FOR CONSTRUCTION PURPOSES)

Model	Motor Frame	S	M	N	D	Impeller Size	CP		B		C	D ₂	HB	HF
							Small	Large	Small	Large				
	NEMA													
UC1516	143	1 1/2	5/8	3 7/8	1	6	23.43	-	8.46	-	10.97	5.25	30.50	28.00
UC1516	184	1 1/2	5/8	3 7/8	1	6	27.00	28.75	8.56	10.21	14.54	5.25	30.50	28.00
UC1516	215	1 1/2	5/8	3 7/8	1	6	30.19	31.19	9.21	10.21	16.98	5.25	30.50	28.00
UC1516	256	1 1/2	5/8	3 7/8	1	6	-	35.68	-	10.21	21.47	6.25	39.00	36.50
UC1518	143	1 1/2	5/8	3 7/8	1	8	23.54	-	8.57	0.00	10.97	5.25	30.50	28.00
UC1518	184	1 1/2	5/8	3 7/8	1	8	27.11	28.86	8.57	10.32	14.54	5.25	30.50	28.00
UC1518	215	1 1/2	5/8	3 7/8	1	8	30.30	31.31	9.32	10.32	16.98	5.25	30.50	28.00
UC1518	256	1 1/2	5/8	3 7/8	1	8	-	35.79	9.32	10.32	21.47	6.25	39.00	36.50
UC326	143	3	3/4	6	2	6	23.76	-	8.79	-	10.97	5.36	30.50	28.00
UC326	184	3	3/4	6	2	6	27.33	29.08	8.79	10.54	14.54	5.25	30.50	28.00
UC326	215	3	3/4	6	2	6	30.52	31.52	9.54	10.54	16.98	5.25	30.50	28.00
UC326	256	3	3/4	6	2	6	-	36.01	-	10.54	21.47	6.25	39.00	36.50
	IEC													
UC1516	80	38.10	15.88	98.43	25.40	152.40	571.48	-	214.86	-	255.02	133.35	774.70	711.20
UC1516	90	38.10	15.88	98.43	25.40	152.40	608.31	-	214.86	-	291.85	133.35	774.70	711.20
UC1516	110/112	38.10	15.88	98.43	25.40	152.40	666.47	-	214.86	-	350.01	133.35	774.70	711.20
UC1516	132	38.10	15.88	98.43	25.40	152.40	730.48	755.88	233.91	259.31	394.97	133.35	774.70	711.20
UC1516	160	38.10	15.88	98.43	25.40	152.40	-	850.88	-	259.31	489.97	160.00	990.60	927.10
UC1518	80	38.10	15.88	98.43	25.40	203.20	574.30	-	216.68	-	255.02	133.35	774.70	711.20
UC1518	90	38.10	15.88	98.43	25.40	203.20	611.27	-	217.68	-	291.85	133.35	774.70	711.20
UC1518	110/112	38.10	15.88	98.43	25.40	203.20	669.29	-	217.68	-	350.01	133.35	774.70	711.20
UC1518	132	38.10	15.88	98.43	25.40	203.20	733.30	758.70	236.73	262.13	394.97	133.35	774.70	711.20
UC1518	160	38.10	15.88	98.43	25.40	203.20	-	853.70	-	262.13	489.97	160.00	990.60	927.10
UC326	80	76.20	19.05	152.40	50.80	152.40	579.81	-	223.19	-	255.02	133.35	774.70	711.20
UC326	90	76.20	19.05	152.40	50.80	152.40	616.64	-	223.19	-	291.85	133.35	774.70	711.20
UC326	110/112	76.20	19.05	152.40	50.80	152.40	674.80	-	223.19	-	350.01	133.35	774.70	711.20
UC326	132	76.20	19.05	152.40	50.80	152.40	738.81	764.21	242.24	267.64	394.97	133.35	774.70	711.20
UC326	160	76.20	19.05	152.40	50.80	152.40	-	859.21	-	267.64	489.97	160.00	990.60	927.10

NOTE: NEMA dimensions are in inches. IEC dimensions are in millimeters.

ACCESSORIES

Baseplates

- Fabricated steel or fiberglass
- Extra strong and rigid
- Suitable for grouting



Digital Power Monitor

For detecting over and under load conditions. Protects against dry running. Includes current transducer and 4-20 mA output for PLC use.

Available in:

3 phase 440-500 VAC

3 phase 220-240 VAC

3 phase 380-420 VAC



UC w/Long Coupled Bearing Frame

Utilizes pump bearing frame and flex coupling between pump and motor

Available in:

Ductile iron construction

Fits ANSI dimensions

Available in regreasable and flood oil lubrications



OTHER FTI PRODUCTS

Sealless Plastic Centrifugal Pumps
Mechanical Sealed Centrifugal Pumps
Stainless Steel Centrifugal Pumps
Drum/Barrel Pumps

Visit www.finishthompson.com to view the full product line.



FINISH THOMPSON INC.

921 Greengarden Road • Erie, PA 16501-1591 U.S.A.

Ph 814-455-4478 • Fax 814-455-8518

Email fti@finishthompson.com • www.finishthompson.com



FT00-806C, Rev 1, 7-2-04