

520 Series Single Stage Sump Pumps

- Capacities to 110 G.P.M.
- Heads to 40 Feet
- Temperatures to 180°F



Introduction

Vertical extended shaft single stage pumps are used to transfer liquid from below-ground reservoirs or enclosed tanks. Aurora 520 Series sump pumps are a logical choice for a variety of applications, such as sump drainage in building basements, tunnels, pits, or wherever water gathers and must be emptied into sewers or be elevated above ground. They are popular for handling wash water, boiler pit service, etc. The 2" pump can handle up to 1-1/2" diameter sphere size screened sewage. Aurora Pump understands that operating speeds, ball bearing arrangements, shaft design and construction are all critical design elements in a vertical pumping system. This brochure illustrates how this pump solves these problems and will contribute to the solution of your particular pumping problem.

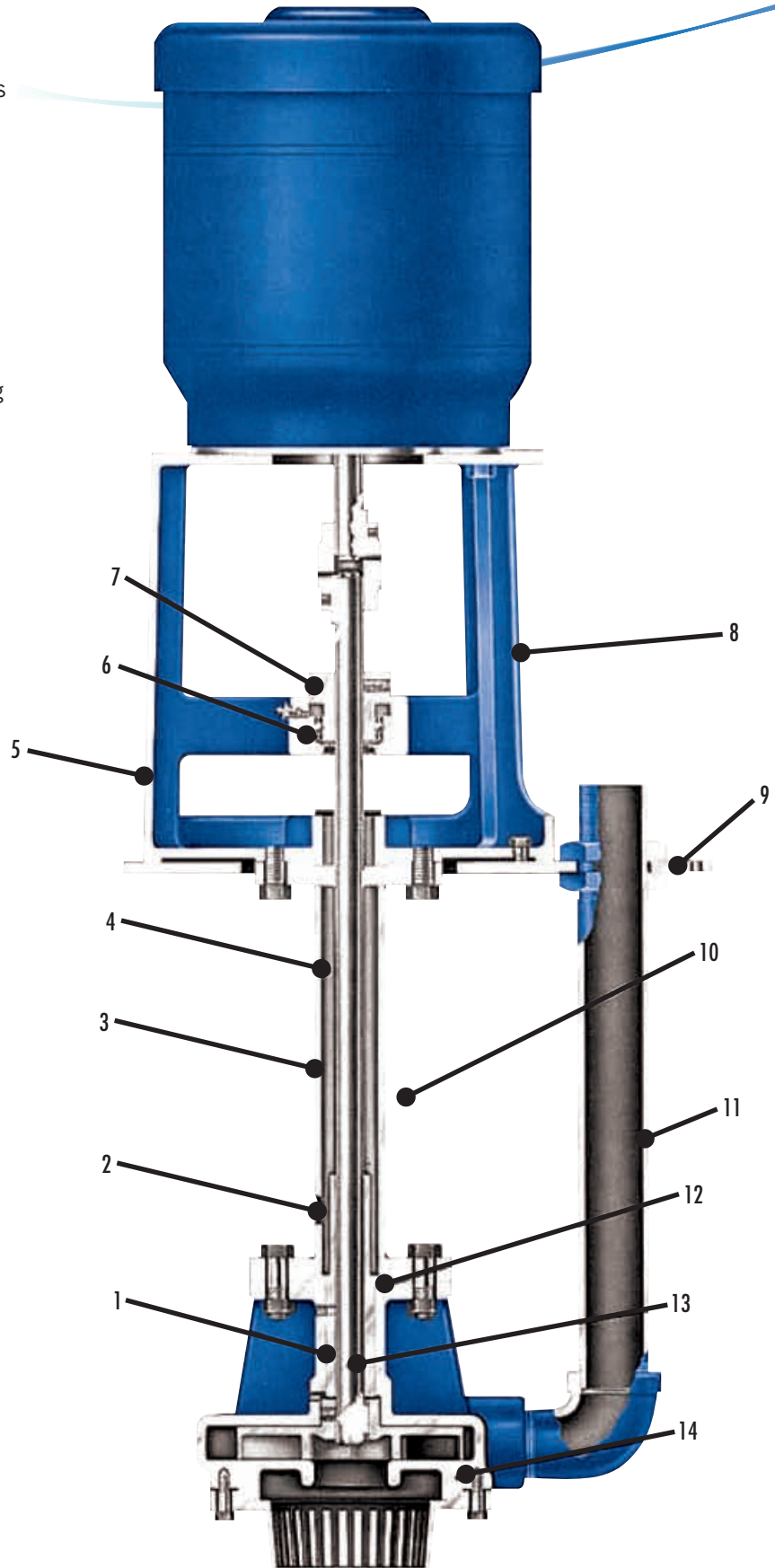

1. Bronze Sleeve Bearing

Extra length for long life.

2. Relief Holes

Prevent liquid under pressure from rising above normal sump liquid levels.

3. Support Pipe

Constructed of 1-1/2" schedule 40 pipe.

4. Line Bearings

Provided for each 4' of depth. Each bearing is grease lubricated.

5. Motor Mounting

Bracket assures alignment of motor and pump shaft with tongue and groove machining.

6. Thrust Ball Bearing

Regreaseable and protected from contamination.

7. External Impeller Adjustment

Accomplished with an easy-to-reach adjusting collar.

8. Elevated Head Bearing

Provides additional bearing protection from washdown and other contaminants. Integral stuffing box is available with packing and a split gland for gastight construction.

9. Steel Baseplate

Standard, with optional designs available.

10. Elevated Float Switch Assembly

Standard, with several available enclosures.

11. Discharge Pipe

Securely locked to the baseplate and threaded.

12. Positive Alignment Throughout

Tongue-and-groove design assures true and vibration-free operation.

13. Pump Shaft

13/16" diameter shaft minimizes deflection.

14. Liquid End

Semiopen bronze impeller is standard. A large area strainer keeps trash from clogging the impeller on 1" and 1-1/2" pumps.

Optional Equipment

- All iron construction
- Gastight stuffing box
- Grease lubricated pump bearing
- Stainless steel shaft
- Round, square or Simplex shape baseplates
- 4" Vent
- Various float switch enclosures
- Electric controllers
- High water alarm
- Float guard
- Special pump setting increments
- Flanged discharge elbow
- Strainer optional on 2" pumps

Pump Performance & Special Features

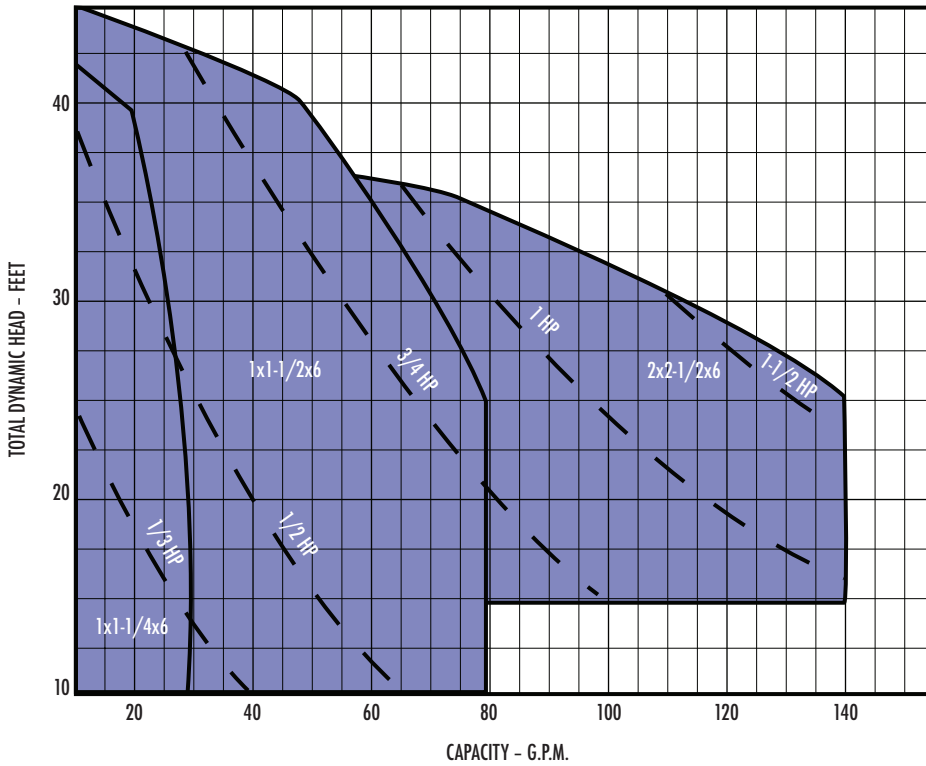

NOTE: Total head calculations must include distance from floor plate to lowest water level.

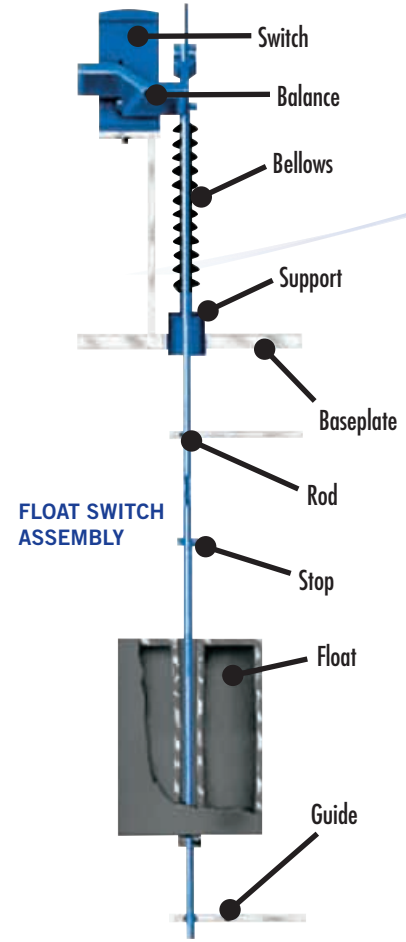

Design Details

Pump Shaft	Rotation – From Driver End	CW
	Diameter – Full Length	13/16
Bearing	Bearing (Ball) – Head	7305W
	Bearing (Sleeve) – Pump	6 Lg.
Support Pipe Size		1-1/2
Speed – RPM		1750
Minimum Horsepower		1/2
Temperature – °F		180
Basin Pressure – psi		2
Basin Cover Size – without oval or manhole		28"
Ovals or Manhole		53"

Line Shaft Bearings

Pit Depths	Number of Line Shaft Bearings
1'4" to 5'1"	0
5'2" to 9'0"	1
9'1" to 10'6"	2

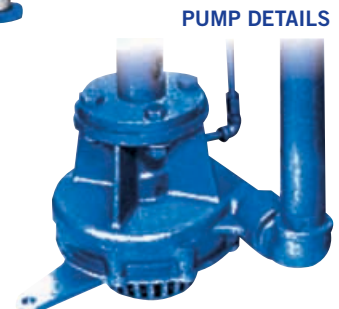

Pump Dimensions

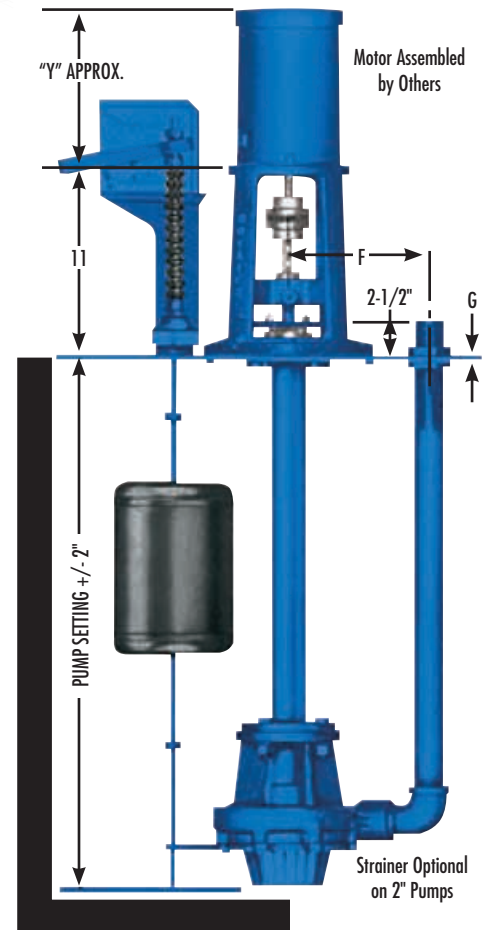
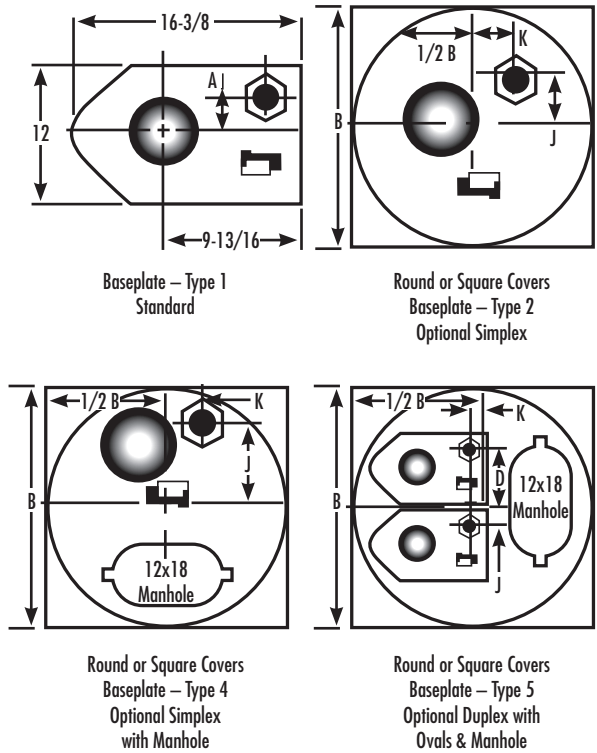

A	B	Steel Baseplate								Motor – O.D.P.				
		Type 1		Type 2		Type 4		Type 5		Frame	Horsepower		Weight (lbs.)	Y
		G	Weight	G	Weight	G	Weight	G	Weight		1750	1150		
–	Oval	1/4	20	–	–	–	–	–	–	–	–	–	–	–
11	24	–	–	3/8	28	–	–	–	–	56	1/3	–	18	10
13	28	–	–	3/8	76	–	–	–	1/2		1/3	20		
16	34	–	–	–	–	3/8	125	1/2	135		3/4	1/2	26	
19	40	–	–	–	–	3/8	173	1/2	183	143TC	1	3/4	37	9-1/2
22	46	–	–	–	–	3/8	299	1/2	309	145TC	1-1/2	1	46	10-1/2
25-1/2	53	–	–	–	–	3/8	397	1/2	504		2	1-1/2		

- NOTES:**
1. Dimensions and weights are approximate.
 2. All dimensions are in inches and may vary +/- 1/2".
 3. Not for construction purposes unless certified.
 4. Add pump(s), base(s), head and motor weight(s) for unit weight.

Pump Size			Pump Weight				Minimum Baseplate Size									
Discharge	Suction	Case Bore	Sphere Size	5'0" Pit Depth	Add for Ea. Add'l. 1' Pit	F	Type 1	Type 2			Type 4			Type 5		
							H	Size	J	K	Size	J	K	Size	D	J
1	1-1/4	6	5/16	190	15	6-1/8	3-5/16	24	4-5/16	3-7/8	30	10-5/16	3-7/8	34	9-5/16	2-13/16
1-1/2	2	6	5/16	195	15	6-3/8	3-1/2		4-3/4	4-3/8		10-3/4	4-3/8		9-5/8	2-5/8
2	2-1/2	6	1-1/2	200	15	6-3/8	3-1/2		4-3/4	4-3/8		10-3/4	4-3/8		9-5/8	2-5/8

Engineering Specifications

The contractor shall furnish (and install as shown on the plans) Aurora Model (521A Simplex) (522A Duplex) centrifugal sump pumps size ____ x ____ of (bronze fitted) (all iron) construction. Each pump shall have a capacity of ____ G.P.M. at ____ ft. total head, with a temperature of ____ °F, ____ specific gravity.

The units shall be designed for a sump depth of ____ feet and shall be furnished with the discharge terminating at the baseplate with a male threaded connection.

A steel baseplate (round) (square) – (Simplex) (Simplex with manhole) (Duplex with manhole) will be provided.

The pump casing and suction cover shall be of cast iron. The casing is to be of the single stage design and cast integrally with the bearing cover.

A strainer of sufficient size (optional on 2" pumps) shall be provided. The impeller is of the semiopen type and shall be constructed of bronze. The impeller is to be dynamically balanced and keyed to the pump shaft. The column pipe must be 1-1/2" diameter having machined tongue and grooved joints to ensure shaft alignment. A pump bearing will be located directly above the impeller and shall be of the bronze sleeve type.

Line bearings must be provided on pit depths of 5'2" and one additional bearing for each 4' thereafter. Line bearings must be (grease) (oil)

(water) lubricated through separate nylon tube lubrication lines terminating at the baseplate.

The motor pedestal is to be of cast iron, one piece construction, fitted with a sealed thrust ball bearing located 3" above the baseplate. An optional packed stuffing box complete with a split gland shall be provided for gas-tight construction. The ball bearing collar is to allow external axial adjustment of the shaft and impeller. A grease seal shall be provided to retain grease and to prevent contamination of the ball bearing. A grease fitting will be provided to allow regreasing of the bearing.

The pump shall be controlled by an enclosed (heavy-duty) (watertight and explosion resisting) (heavy-duty with built-in overload protection) (explosion-proof) type float operated switch 6" above the baseplate with reinforced plastic float and float rod. A flexible bellows will provide gastight construction.

An automatic alternator shall be furnished on duplex pumps to allow the pumps to alternate on each successive cycle of operation. The pumps are to be driven by and flexible coupled to a standard "C" flange ____ HP, ____ volt, ____ cycle, ____ RPM, ____ enclosure, vertical electric motor.

NOTE: Aurora Pump reserves the right to make revisions to its products and their specifications, and to this bulletin and related information, without notice.

800 AIRPORT ROAD • NORTH AURORA, ILLINOIS U.S.A. • 60542
PHONE: (630) 859-7000 U.S.A./CANADA FAX: (630) 859-7060
WORLDWIDE FAX: (630) 859-1226

WEB: www.aurorapump.com

