



A Division of Met-Pro Corporation

BULLETIN 402
SETHCO
STAINLESS STEEL
FILTER CHAMBERS
 FOR FILTRATION OF
 CORROSIVE LIQUIDS

FEATURES

- Filters light or heavy fluids to microscopic clarity.
- Heavy duty one piece welded chamber design.
- All 316 Stainless Steel construction.
- Filtration to 2700 GPH (10,220 LPH) at temperatures to 210°F.(99°C.)
- Pressure to 150 PSI. (10kg./cm.²)
- Fast and easy filter tube change over.

APPLICATIONS

- Corrosive Liquids
- Oils and Solvents
- Paints and Lacquers
- Pharmaceuticals
- Photographic Solutions
- Plating Solutions
- Water Purification

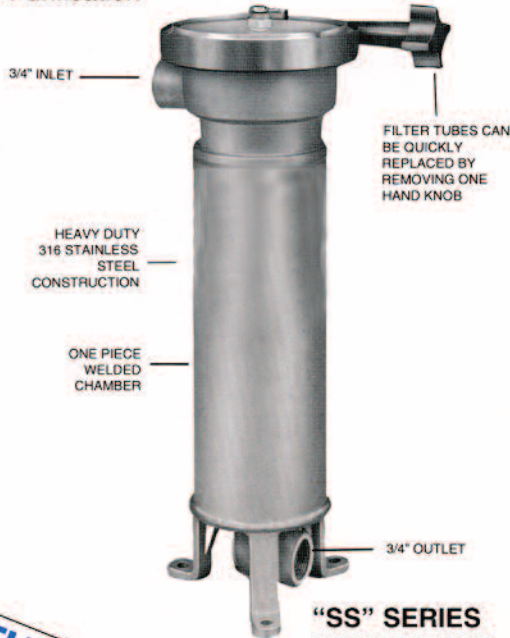

**“SS” SERIES
 SINGLE TUBE
 CHAMBERS**

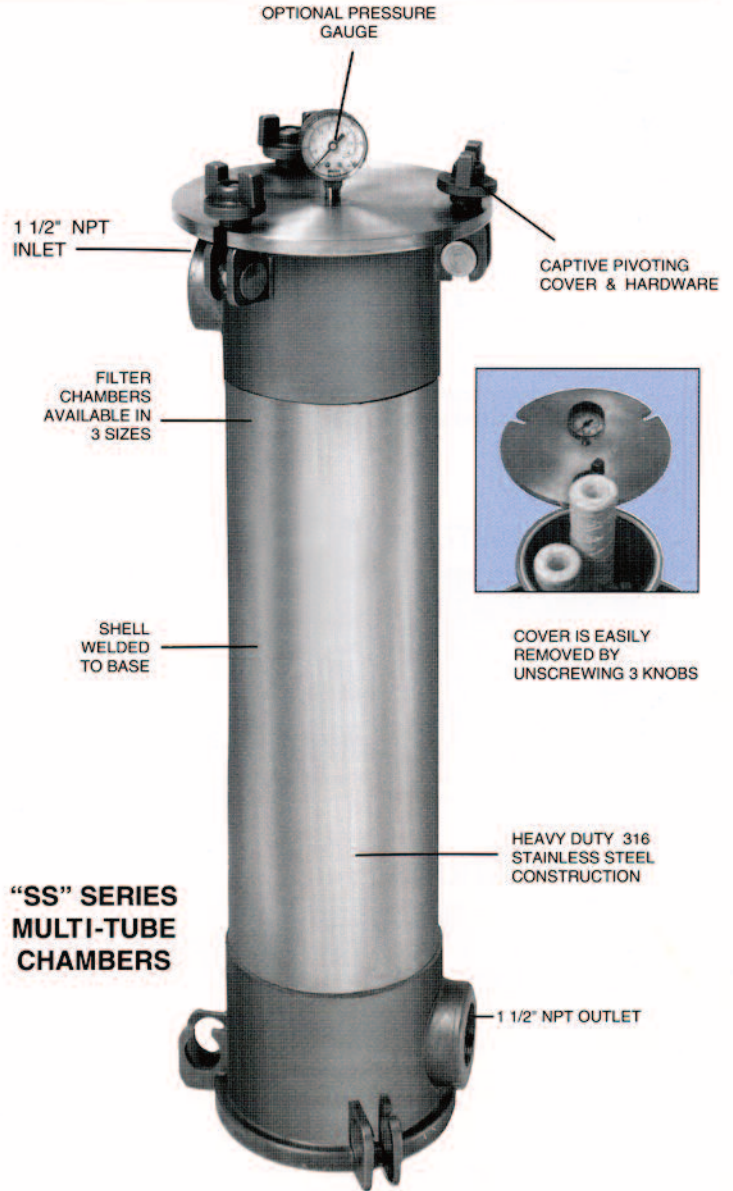

**“SS” SERIES
 MULTI-TUBE
 CHAMBERS**

**THREE NEW MODELS,
 FLOWS TO 2700 GPH (10,220 LPH)**

WARRANTY: One year warranty against defective parts and workmanship. See Form TC-O1 for full warranty details. Always be specific about your application in order that proper materials may be furnished. Let Mefiag or an authorized distributor know; liquids being handled, gallons, temperatures and pH.
 The standard warranty does not apply when equipment is used contrary to factory recommendations. Since the policy of Mefiag is one of continual improvement, we reserve the right to change design or materials at any time, without giving notice or creating any obligation to previous or future customers.

Sethco STAINLESS STEEL FILTER CHAMBERS FOR CORROSIVE LIQUID FILTRATION

CORROSION RESISTANT STAINLESS STEEL CONSTRUCTION

Sethco's "SS" Series stainless steel filter chambers are available in 6 models in capacities from 120 to 2700 GPH (454 to 10,220 LPH) for filtering light or heavy fluids to microscopic clarity at pressures to 150 psi (10kg/cm²). Corrosion resistant type 316 stainless steel construction makes Sethco's filter chambers suitable for filtering most corrosive aqueous or organic liquids without product contamination. Viton O-rings are standard, Teflon is optional. These chambers are suitable for a wide range of applications including solvents, alkalies, and some acids and offer quick, easy filter change over.

FILTER TUBES

Choose from cotton or polypropylene, depending on your application. Filter tubes are available in a wide variety of sizes for controlled filtration from 150 microns down to 1 micron. Standard densities are coarse 50 micron, medium 25 micron, fine 15 micron, x-fine 10 micron and 1-3 micron. Unless specified, chambers are provided with a set of cotton filter tubes with SS cores.

Cotton filter tubes are recommended for moderately acid and moderately alkaline solutions pH 3-11.

Polypropylene filter tubes are recommended for concentrated acid and alkaline solutions.

For complete specifications on filter tubes, see Bulletin 901.

For carbon tubes, see Bulletin 913.

FILTRATION SYSTEMS WITH SETHCO PUMPS

For carbon tubes, see Bulletin 913. Sethco 316 stainless steel pumps come in a variety of sizes to accommodate any Sethco "SS" series filter chamber. Complete systems are mounted on a corrosion resistant panel with ball bearing swivel casters and are shipped completely assembled and tested, ready for immediate start-up.

Visit www.sethco.com for ss pump details, or see Bulletin 702 for system details.

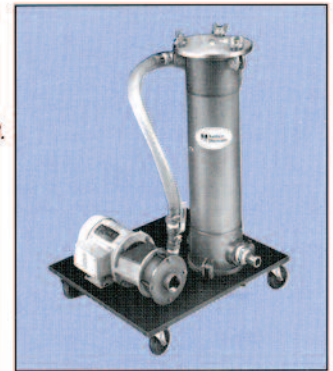

OPTIONAL EQUIPMENT

A stainless steel pressure gauge can be added to all chambers. Teflon O-rings are available for all models. A set of mounting pins are available for 3 tube models to facilitate mounting chambers to a panel or baseplate.



CHANGE FILTER TUBES IN MINUTES (three tube chamber illustrated)



1. Unscrew 3 hand knobs and pivot knobs away from cover.



2. Swivel chamber cover open.



3. Unscrew filter tube cap nuts.

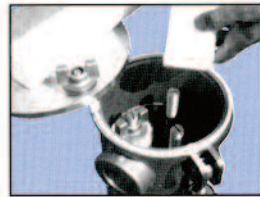

4. Remove spent tubes from chamber.



5. Drop in new tubes, replace tube cap nuts and secure cover.

SPECIFICATIONS

| MODEL | NO. OF TUBES | APPROX. CAPACITY* | | | | INLET AND OUTLET NPT | OVERALL HEIGHT | | MAXIMUM DIAMETER | | WEIGHT NET | |
|--------|-------------------|-------------------|-----|-----------------|------|-------------------------|----------------|-----|------------------|----|------------|--------|
| | | LIGHT FLUIDS | | VISCIOUS FLUIDS | | | IN | CM | IN | CM | LBS. | KILOS. |
| | | GPM | LPM | GPM | LPM | | | | | | | |
| SS-110 | 1 # 10 | 5 | 19 | 2 | 7.5 | 3/4" | 15 1/16 | 38 | 5 1/4 | 13 | 12 | 5.4 |
| SS-120 | 1 # 20 (or 2 #10) | 10 | 38 | 5 | 19 | 3/4" | 25 3/8 | 64 | 5 1/4 | 13 | 14 | 6.3 |
| SS-130 | 1 # 30 (or 3 #10) | 15 | 59 | 7 | 26.5 | 3/4" | 25 11/16 | 65 | 5 1/4 | 13 | 16 | 7.2 |
| SS-310 | 3 # 10 | 15 | 57 | 7 | 26 | 1 1/2" | 20 | 50 | 10 | 25 | 63 | 28.6 |
| SS-320 | 3 # 20 or 6 # 10 | 30 | 113 | 15 | 57 | 1 1/2" | 30.5 | 77 | 10 | 25 | 67 | 30.4 |
| SS-330 | 3 # 30 or 9 # 10 | 45 | 170 | 22 | 79 | 1 1/2" | 40.5 | 103 | 10 | 25 | 75 | 33.2 |

* Capacity varies according to temperature, pressure, viscosity, nature of liquid and nature and percentage of contaminant. Capacities cited above are for average normal operating conditions with light fluids or aqueous consistency or viscous fluids of the consistency of lubricating oil.



A Division of Met-Pro Corporation

1550 Industrial Road, Owosso, MI 48867

989-725-8184 • Fax: 989-729-1013

Website: www.mefiag.com • Email: mefiag@met-pro.com