

Series: PFSPTM3

Self-Priming Centrifugal Pumps
Size: 3" x 3", Solids 2-1/2"



Series: PFSPTM3

Size: 3" x 3"
Self-Priming
Centrifugal Pumps

Description

Self priming centrifugal solids handling pumps designed for Municipal and Industrial applications.

NET WEIGHT	SHIPPING WEIGHT	EXPORT CRATE
434 lbs	482 lbs	14.1 cu ft.

SUCTION & DISCHARGE	3" x 3", ASA 125lb Spool Flanges included for Suction & Discharge
LIQUID TEMPERATURE	160°F
CASING	Gray Iron ASTM A-48 Class 30 Maximum Operating pressure 87 psi
IMPELLER	2 Vane open type. <i>Material:</i> Ductil Iron, Handles 2-1/2" diameter spherical solids
SHAFT	Alloy Steel
SHAFT SLEEVE	316 Stainless Steel
COVER PLATE	Gray Iron ASTM A-48, Class 30, Removable, Adjustable, Weight 30 lbs.
WEAR PLATE	Replaceable, Steel
FLAP VALVE	Neoprene with steel reinforcing
BEARING HOUSING	Gray Iron ASTM A-48, Class 30
SEAL PLATE	Gray Iron ASTM A-48, Class 30
BEARING - PUMP END	Open single ball, radial load
BEARING - DRIVE END	Open single ball, thrust load
LUBRICATION	Bearing - SAE No. 30 non detergent oil, pump includes oil level sight gauge
GASKETS	Buna-N, compressed synthetic fibers, PTFE, vegetable fiber, cork and rubber
O-RINGS	Buna-N
HARDWARE	Standard plated steel
PRESSURE RELIEF VALVE	Brass
SEAL	Cartridge Type, mechanical, oil lubricated. <i>Material:</i> Tungsten carbide rotating and stationary faces, Viton elastomers (Dupont Viton® or equivalent). 316 Stainless steel cage and spring
OPTIONAL EQUIPMENT	Flexible coupled assy, with base OSHA guard and electric motor.

WARNING ! - DO NOT use in explosive atmosphere or for pumping volatile flammable liquids.

IMPELLER SIZES: Standard Impeller will be supplied unless otherwise noted.

8.75" Dia. - Standard 8.50" Dia. 8.25" Dia. 8.00" Dia. 7.75" Dia.

Series: PFSPTM3



Self-Priming Centrifugal Pumps
 Size: 3" x 3", Solids 2-1/2"

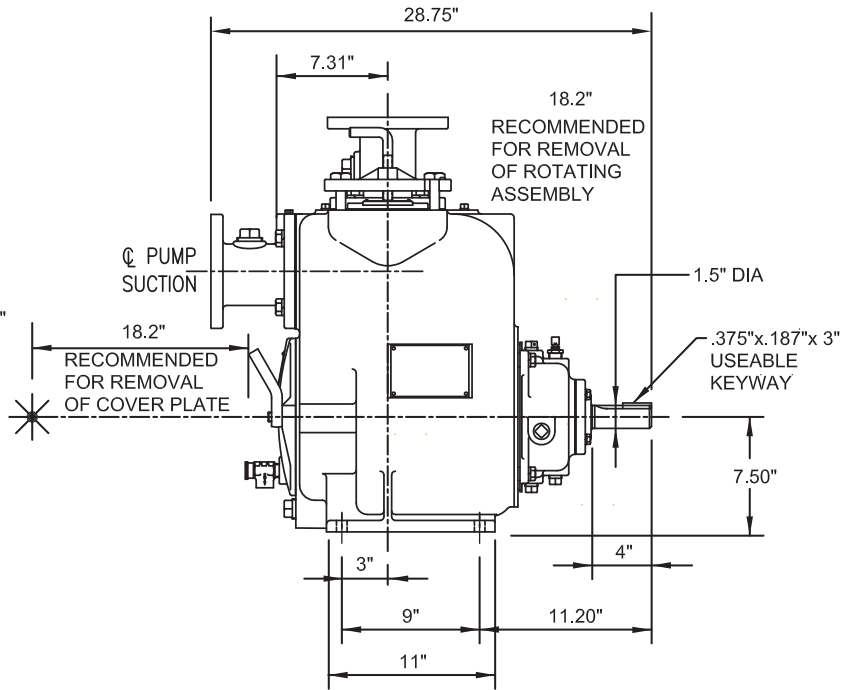
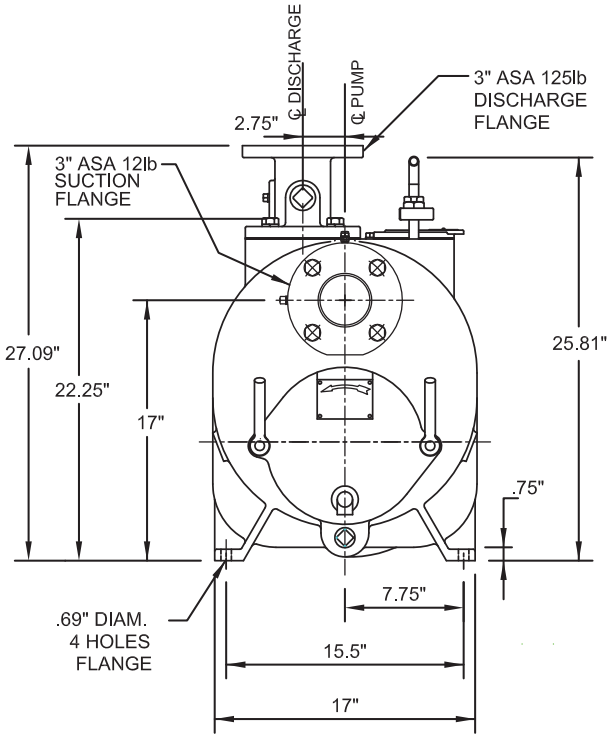

8.75" Impeller Dia - Standard, Various RPM

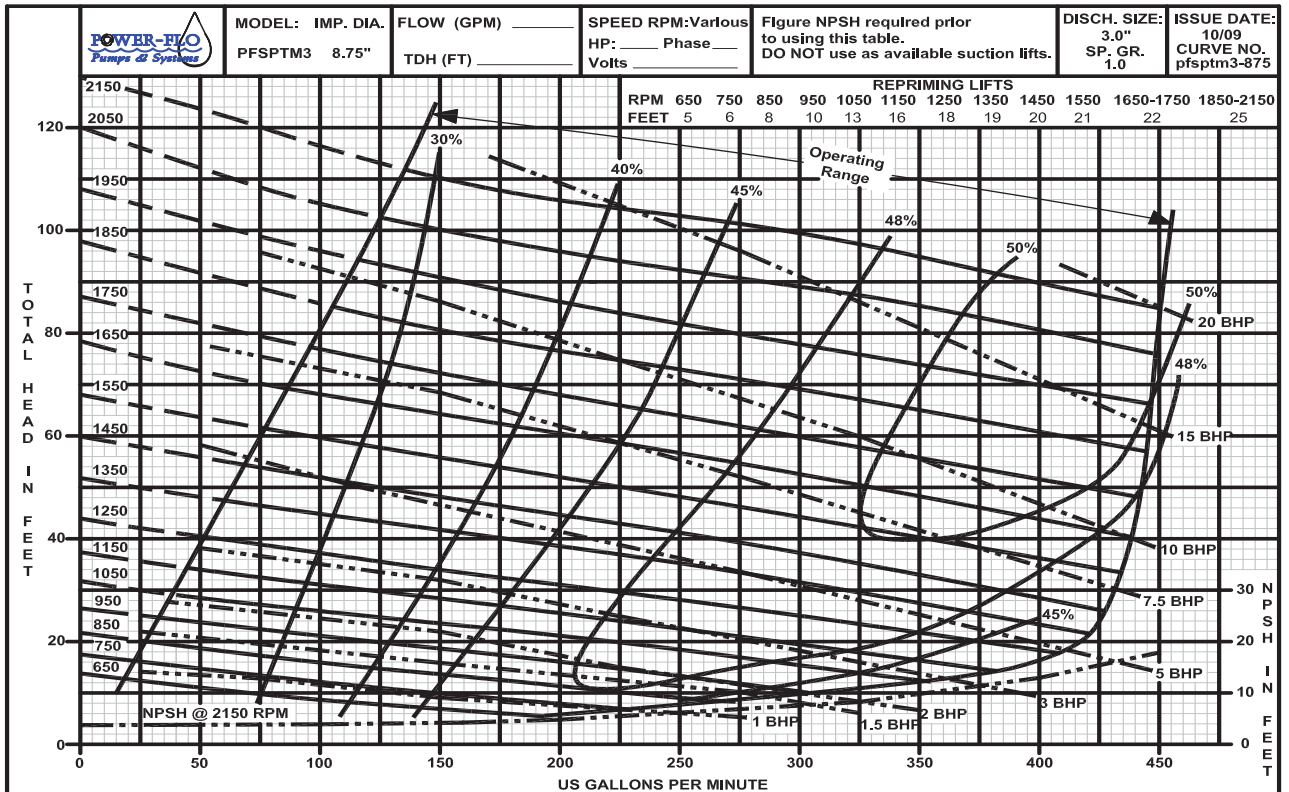



Series: PFSPTM3

**Self-Priming Centrifugal Pumps
8.50" & 8.25" Dia. Imp. at Various RPM**

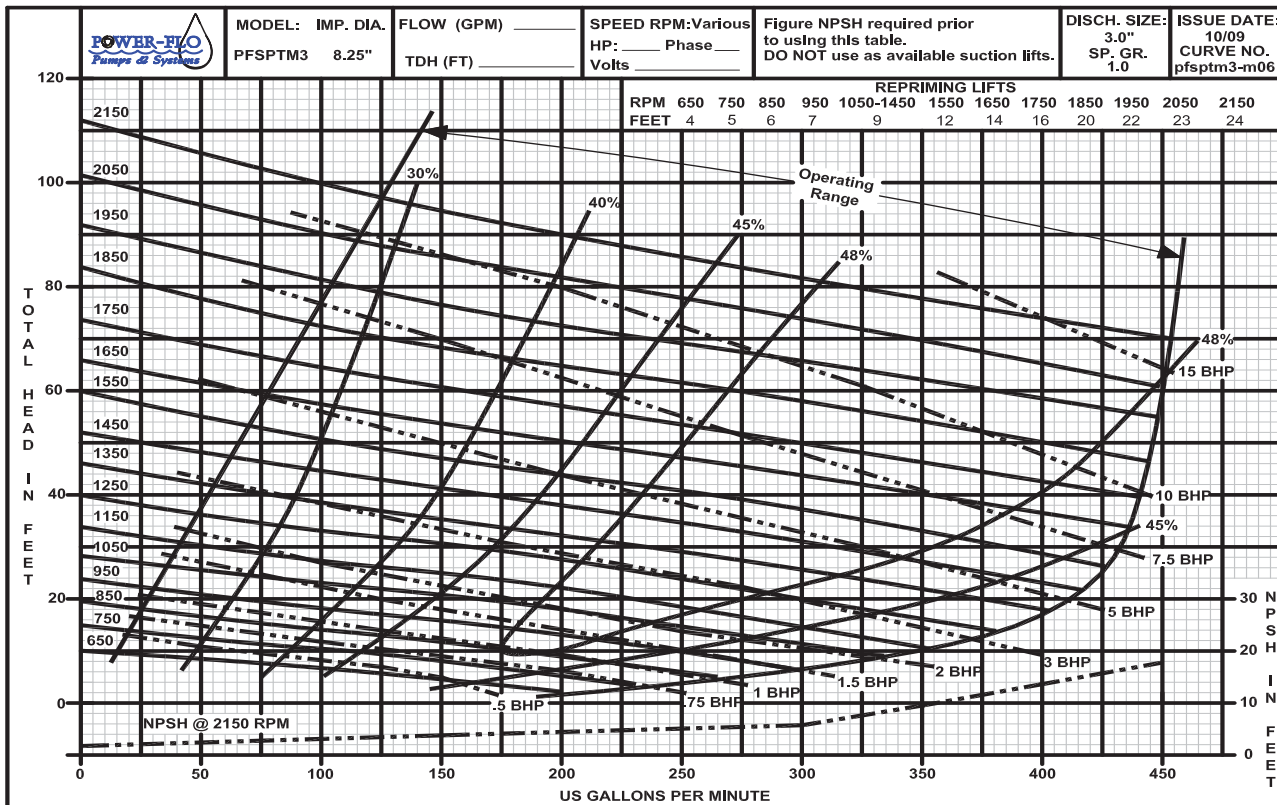
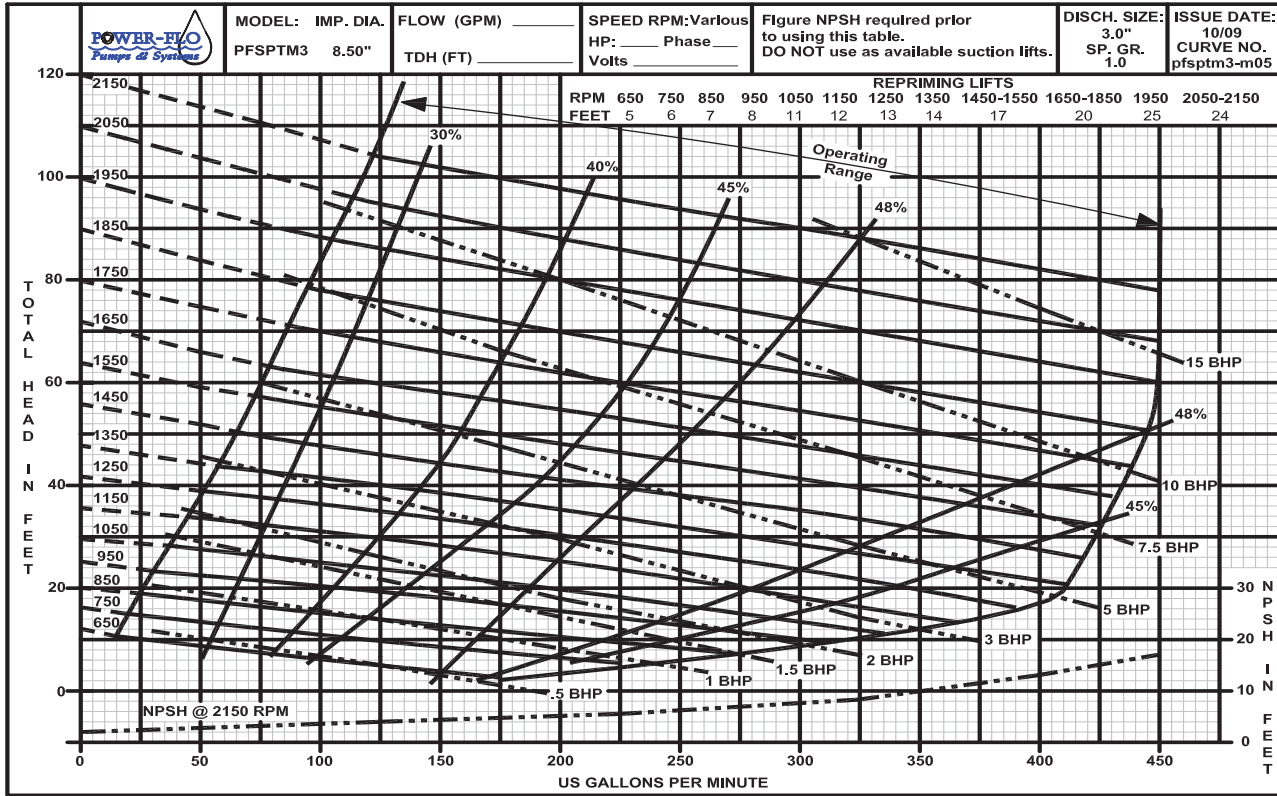

Series: PFSPTM3

Self-Priming Centrifugal Pumps
8.00" & 7.75" Dia. Imp. at Various RPM

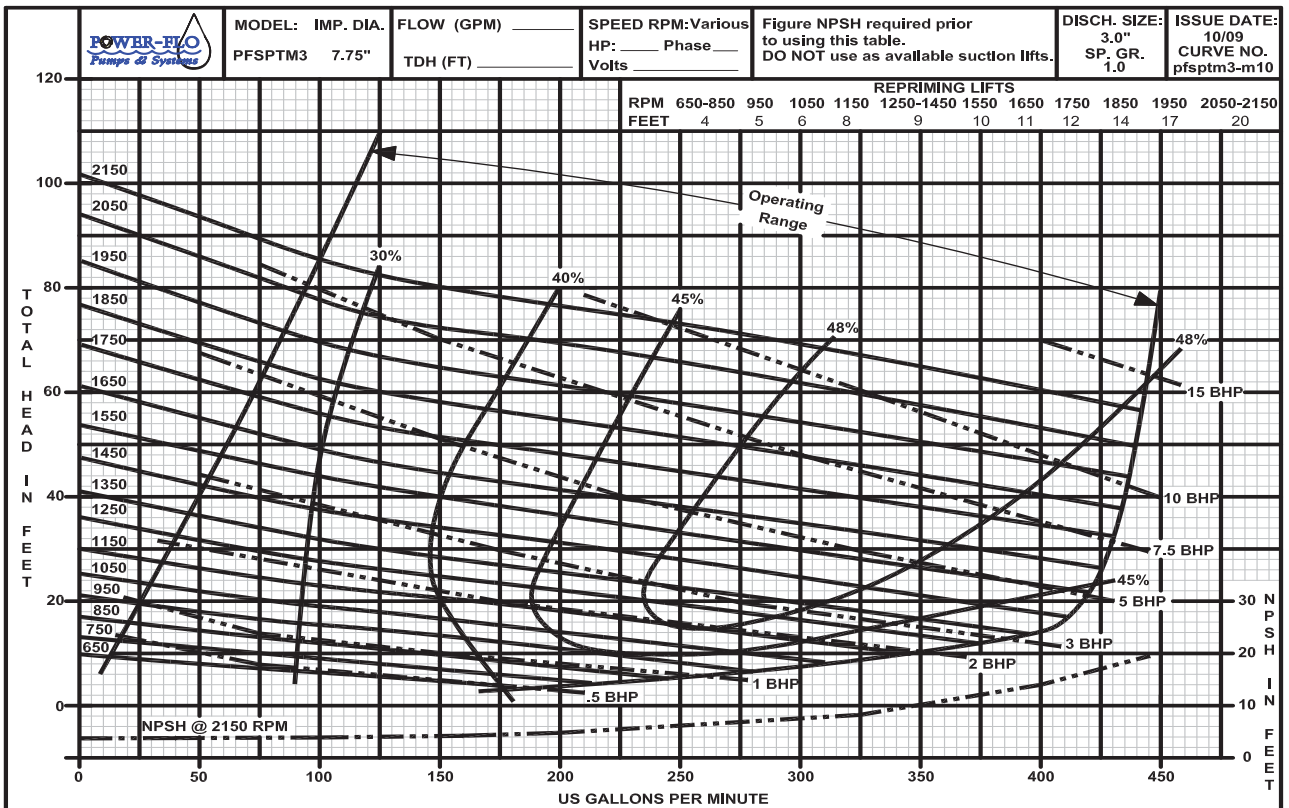
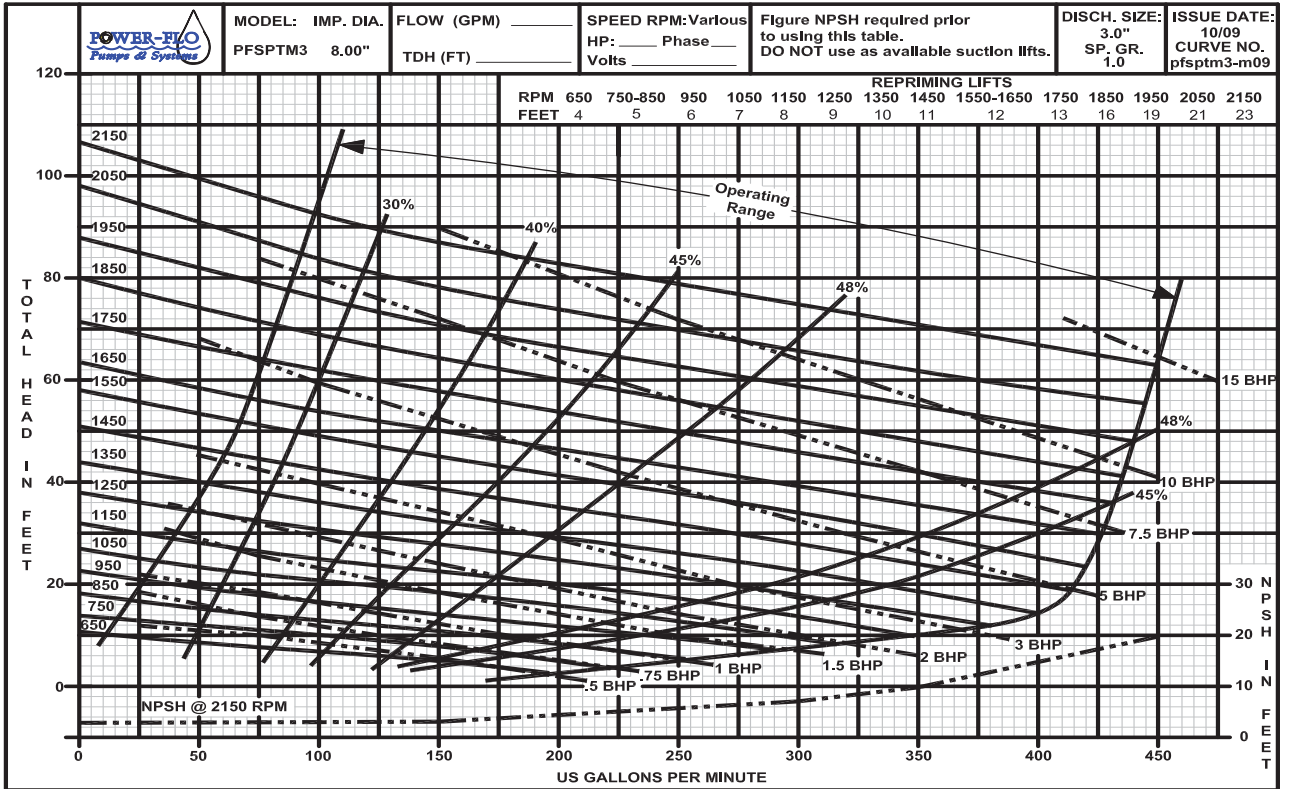



Series: PFSPTM3

**Self-Priming Centrifugal Pumps
Various Impeller Dia, 1750RPM & 1450RPM**

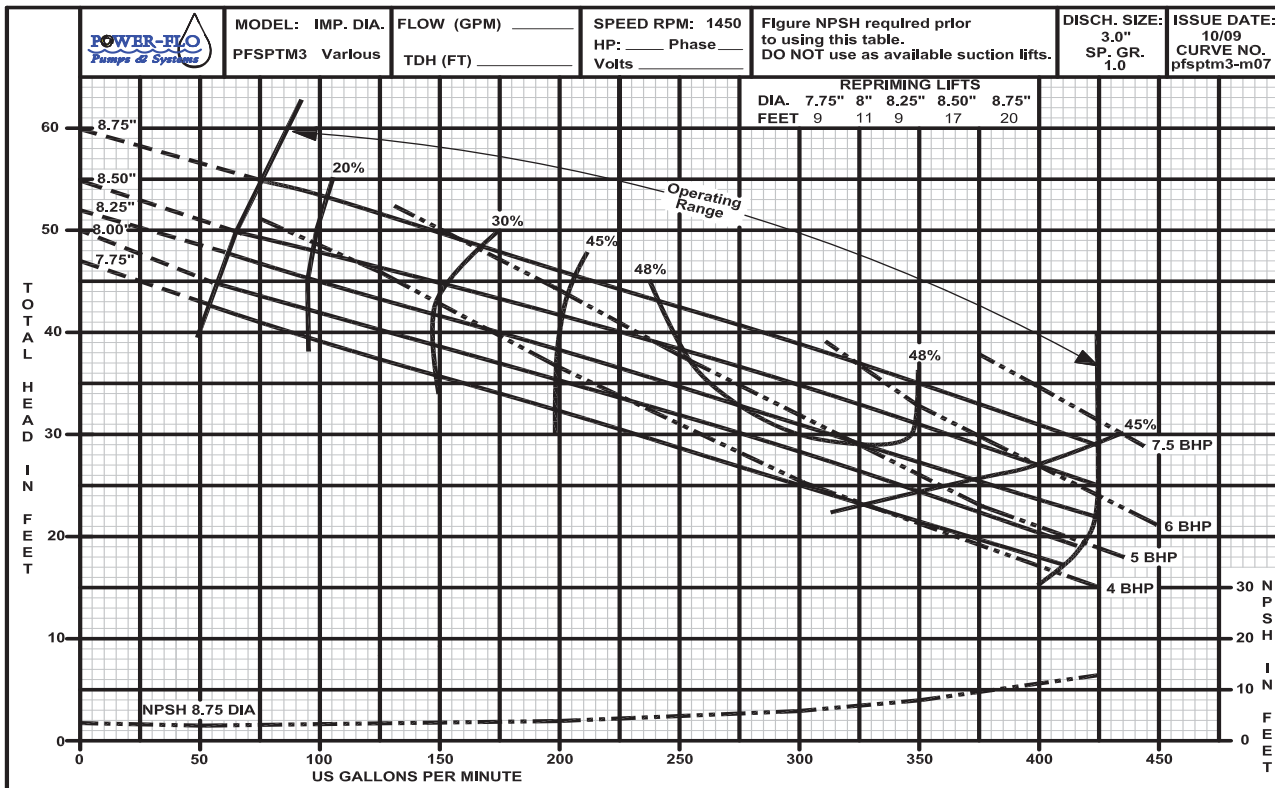
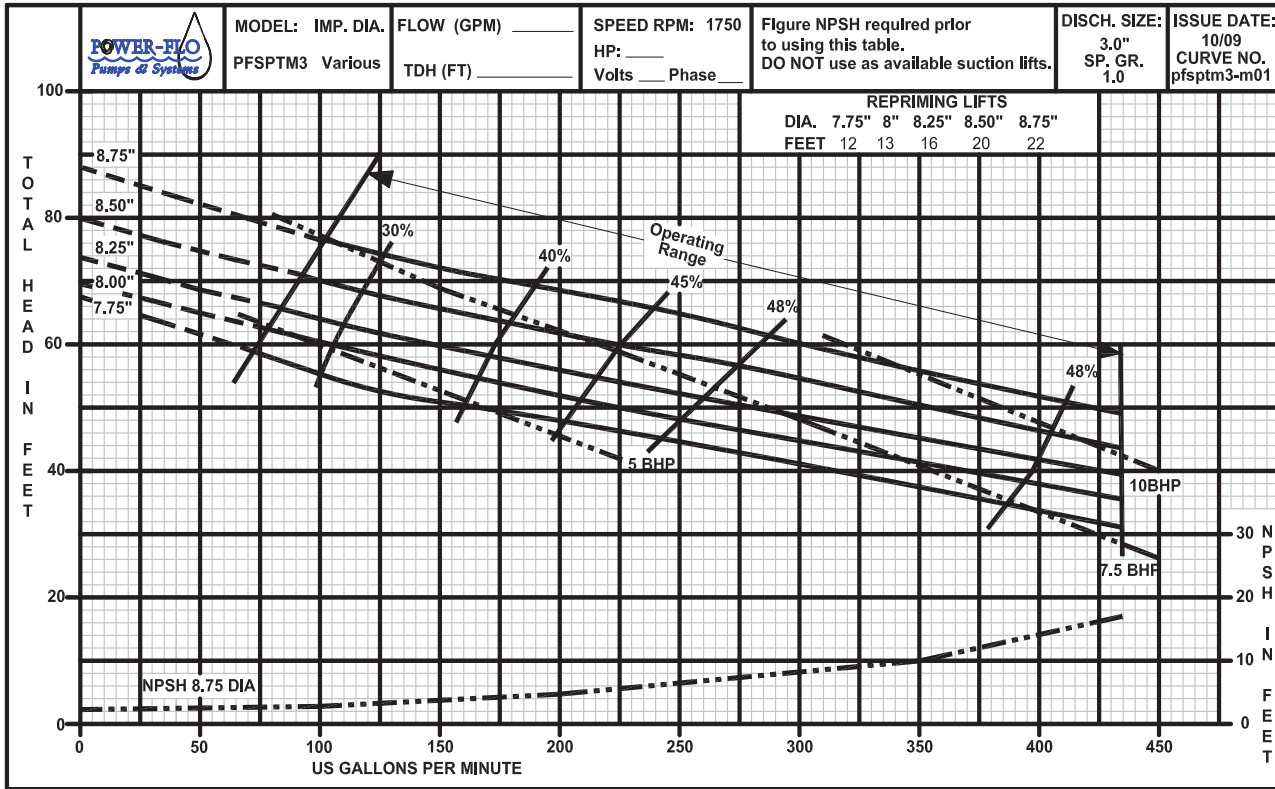

Series: PFSPTM3

Self-Priming Centrifugal Pumps
Various Impeller Dia, 1150RPM & 950RPM

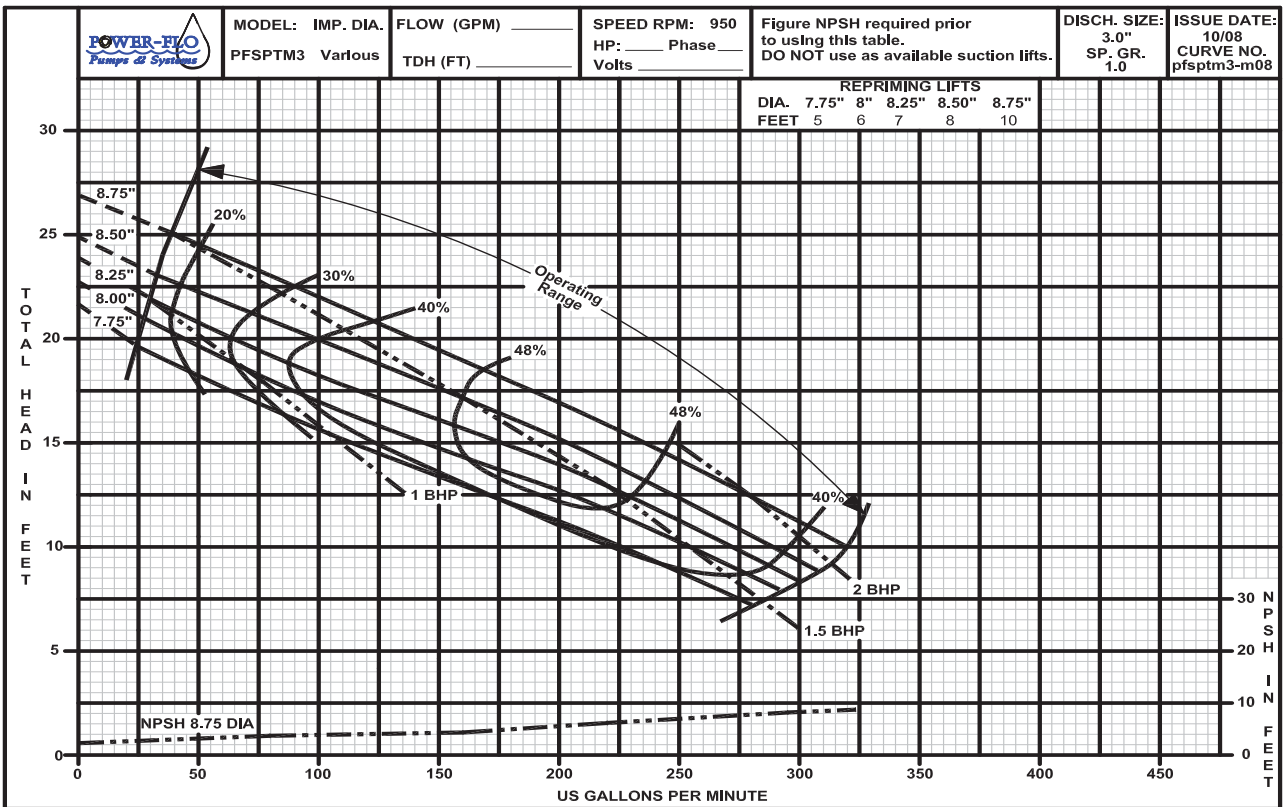
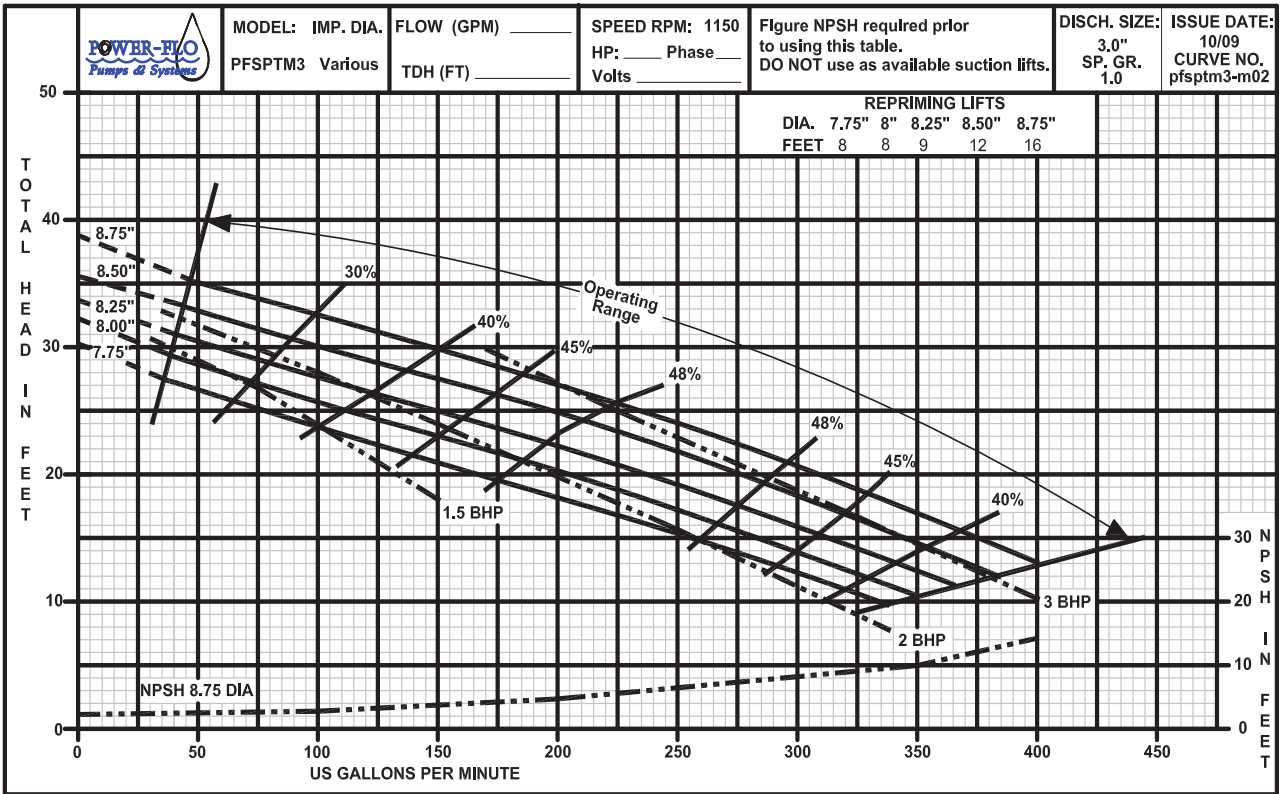



Series: PFSPTM3

Self-Priming Centifugal Pumps
Various Impeller Dia, 860RPM

